



European Technical Assessment

ETA 20/0275 of 27/07/2023



English version prepared by Itecons

General Part

Technical Assessment Body issuing the European Technical Assessment:

Itecons - Instituto de Investigação e Desenvolvimento Tecnológico para a Construção, Energia, Ambiente e Sustentabilidade

Trade name of the construction product	SINUSPROTECT MGSI® ALPHA MGSI® M-MGSI®
Product family to which the construction product belongs	Structural Metallic Products and Ancillaries Product area code: 20
Manufacturer	MGSI, Acessórios para Indústrias, Lda. Rua do Arneiro, n.º 73 3105-121 Ilha, Pombal Portugal
Manufacturing plant	MGSI, Acessórios para Indústrias, Lda. Rua do Arneiro, n.º 73 3105-121 Ilha, Pombal Portugal
This European Technical Assessment contains	46 pages including two Annexes which form an integral part of this assessment
This European Technical Assessment is issued in accordance with regulation (EU) No 305/2011, on the basis of	EAD 200089-00-0302 <i>In-situ concrete slab permanent joint former</i>
This version replaces	ETA 20/0275, version 1 issued on 08/05/2020

Translations of this European Technical Assessment in other languages shall fully correspond to the original issued document and should be identified as such.

Communication of this European Technical Assessment, including transmission by electronic means, shall be in full (excepted the confidential Annex(es) referred to above). However, partial reproduction may be made, with the written consent of the issuing Technical Assessment Body. Any partial reproduction has to be identified as such.

Specific parts

1. Technical description of the product

In-situ concrete slab permanent joint formers **SINUSPROTECT MGSİ®**, **ALPHA MGSİ®**, and **M-MGSİ®** are leave-in-place formwork and joint systems supplied in mild, stainless, galvanized steel or a combination of these materials.

These joints, also referred to in this document as MGSİ® joints, provide continuity of reinforcement for ground supported slabs and transfer the loads through the edges of each panel of the slab to another. In addition, these joints will provide protection to slab edges and ensure continuing serviceability of the ground floor slab.

MGSİ® joints are composed of:

- Slab edge protection: to protect edges from impacts;
- Concrete anchorage: can be provided by spikes, zigzag rods or shear studs;
- Divider plate: physically constrains the concrete during the casting;
- Dowels: load transfer mechanisms which are welded to the divider plate.

SINUSPROTECT MGSİ®

SINUSPROTECT MGSİ® joints are used in concrete slabs where the transit of materials handling equipment, such as forklifts for example, may require a smooth crossing between slabs. The slab edge protection is a horizontal plate with a wave shaped split line to ensure that the wheels of the handling equipment are in contact with both sides of the joint while crossing over it. The waved horizontal plate also prevents debris from entering the joint. This system comprises different accessories for the intersection of joints: type T (tee), L (corner) and X (four way). Further information is given in Annex A1.

ALPHA MGSİ®

ALPHA MGSİ® joints are used where protection of the slab edges and load transfer capacity between slabs is required. These joints are characterized by the use of two back-to-back solid steel strips with concrete anchorage. The height and the length of the joint system are defined by the specifications of the slab to be built. These joints may also be filled with polyethylene foam or similar material between the solid steel strips, which allows allowing in-service thermal expansion of the cast slab due to variations in ambient temperature. This system comprises different accessories for the intersection of joints: type T (tee), L (corner) and X (four way). Further information is given in Annex A2.

M-MGSİ®

M-MGSİ® joints have a set of saw-like shaped strips with welded concrete anchorage. They are used in concrete slabs that require a permanent contact of the slab surface with the wheels of handling equipment and provide a greater movement of the slab. This system comprises different accessories for the intersection of joints: type T (tee), L (corner) and X (four way). Further information is given in Annex A3.

Further information on the load transmission devices is given in Annex A4.

The components of the joints are presented in Table 1.

Table 1: Components of the joints

Joint	Component		Material
ALPHA MGSI®	Solid steel strip		EN 10277-2: S235JR+C, S275JR+C or SAE/AISI 1018 A - Calibrated
	Solid steel strip for negative temperatures		S235 and S275 – J2, K2 or L2
	Solid stainless-steel strip		304/316 AISI
	Solid galvanized steel strip		EN 10025-2 S235 JR or S275 JR Galvanization EN ISO 1461
SINUSPROTECT MGSI®	Horizontal steel plate with a wave shaped split line		EN 10025-2 S235 JR or EN 10111-DD11
	Horizontal galvanized steel plate with a wave shaped split line		EN 10025-2 S235 JR or EN 10111-DD11 Galvanization EN ISO 1461
	Horizontal stainless-steel plate with a wave shaped split line		304/316 AISI
	Steel angle bracket		EN 10025-2 S275 JR or higher
	Galvanized steel angle bracket		EN 10025-2 S275 JR Galvanization EN ISO 1461
	Stainless-steel angle bracket		304 / 316 AISI
	“L” shape steel plate bracket (alternative to angle bracket)		EN 10025-2 S235JR
	Galvanized steel bent plate in “L” (alternative to angle bracket)		EN 10025-2 S235 JR Galvanization EN ISO 1461
M-MGSI®	Saw-like shaped steel top strip		EN 10277-2 S235JR+C or S275JR+C
	Galvanized saw-like shaped steel strip		EN 10277-2 S235JR+C or S275JR+C Galvanization EN ISO 1461
	Stainless steel saw-like shaped steel strip		304/316 AISI
For all joints	Divider plate		Polished plate: EN 10130 DC01 Pickled plate: EN 10111-DD11
For all joints	Concrete anchorage - spikes		EN 10025-2 S235JR or S275JR
ALPHA MGSI® SINUSPROTECT MGSI®	Concrete anchorage - zigzag rod	Bended rod	UNE 36066/96 Wire rod Sx08, Sx09, Sx10 and Sx10G
		Ribbed rod	A400, A400 NR SD, A500 ER, A500 NR, A500 NR SD
For all joints	Concrete anchorage – shear studs		EN ISO 13918:2017
For all joints	Dowels		EN 10025-2 S275JR or higher
For all joints	Sleeves		Polypropylene

Joint	Component	Material
For all joints	Accessory for joint intersection	Mechanical tube – EN 10421 Inferior tube - EN 10219-1/2 S235JR
		Anchorage connectors – EN ISO 13918
		Base plate – EN 10025-2 S235JR or higher

2. Specification of the intended use(s) in accordance with the applicable European Assessment Document (hereinafter EAD)

2.1 Intended use

In-situ concrete slab permanent joint formers are leave-in-place formwork that provide continuity of reinforcement in ground supported slabs and transfer the loads from one slab to the next if required, providing a continuum in slab deformation to the required level. In addition, the joints will provide protection to slab edges and ensure continuous serviceability of the ground floor slab.

Slab edges are vulnerable to damage caused by the transit of materials handling equipment, with wider joints being more susceptible. The small hard wheels of pallet trucks and similar equipment are particularly aggressive.

The number and type of joints in a floor will depend on the floor construction method and its design. The chosen method should consider the intended use of the floor, among other factors.

MGSI® joints are free-movement joints, designed to provide a minimum restraint to horizontal movements caused by drying shrinkage and temperature changes in the slab, while restricting relative vertical movement.

2.2 Assumed working life of the construction product

The provisions made in this European Technical Assessment are based on an assumed working life of 50 years as minimum according to the EAD, provided that the conditions laid down for the installation, packaging, transport and storage as well as appropriate use, maintenance and repair are met. The indications given on the working life cannot be interpreted as a guarantee given by the producer, but are to be regarded only as a mean for choosing the right product in relation to the expected economically reasonable working life of the works.

2.3 Manufacturing of the joint formers

The production of MGSI® joint formers and their components is made in accordance with drawings and work instructions; it also encompasses the monitoring of the process, the inspection of the components and the final assembly in accordance with control plans.

2.4 Design

The MGSI® joints may be of standard design or bespoke customized design to provide for the specific project needs. MGSI® joints design is based on the specifications of the intended use, the expected maximum joint opening, the environment, the required load transfer across the joint and the slab thickness.

2.5 Packing, transport and storage

Palletisation of the joint formers is undertaken at the factory by trained personnel in order to ensure the correct transport of the joints.

The information on packing, transport, storage and maintenance is provided in the manufacturer's technical documentation. It is responsibility of the manufacturer to undertake the appropriate measures and to advise his clients on the transport, storage, maintenance, replacement and repair of the product.

3. Performance of the product and references to the methods used for its assessment

The assessment of the MGSI® joints according to the Basic Work Requirements (BWR) was carried out in compliance with EAD 200089-00-0302. The characteristics of the components shall correspond to the respective values laid down in the technical documentation of this ETA, checked by Itecons.

3.1. Mechanical resistance and stability (BWR 1)

3.1.1 Load transfer capacity

The load-transfer capacity depend mainly on the mechanism of the joint. Sub-base support may have some influence, but it is not considered in the design process. Joint mechanisms can be composed of round or square dowel bars, or plate dowels.

The transit of material handling equipment will cause some relative deflection across joints; hence, they should be designed to reduce such deflection to a negligible amount.

The load transfer capacity of the joints depends on the compressive strength of concrete and the geometry and strength of the dowels at yield. Their load transfer capacity was determined according to annex A of EAD 200089-00-0302 and the results are presented in Annex B of this ETA.

3.1.2 Durability

The durability of the product depends on the durability of the materials used. The part of the floor in which the joint systems are intended to be installed or applied must be assessed according to their chemical composition, thickness of material layers, intended use, concrete cover thickness and the environmental exposure to which they are subject. To assess the durability, the following cases must be considered:

- Stainless steel products can be considered fit for purpose from a durability aspect;
- Galvanized or mild steel elements with a minimum 30 mm concrete cover can be considered fit for purpose from durability aspect;
- Galvanized steel must have a minimum of 25 µm galvanized coating if not covered by a minimum of 30 mm concrete cover for floors not exposed to frequently wet or corrosive conditions;
- Galvanized steel must have a minimum of 85 µm galvanized coating if not covered by a minimum of 30 mm concrete cover for continuously wet floors.

If all products assessed comply with these requirements, no further investigation regarding durability is required.

3.1.3 Dimensions, tolerances on dimensions and shape

Dimensional tolerances of MGSI® joints steel components are ± 0.5 mm, as established by the

production control.

The tolerances for angles between the systems components, as established in the production control, are $\pm 0.5^\circ$.

3.2 Safety in case of fire (BWR 2)

Not relevant.

3.3 Hygiene, health and environment (BWR 3)

Not relevant.

3.4 Safety and accessibility in use (BWR 4)

Not relevant.

3.5 Protection against noise (BWR 5)

Not relevant.

3.6 Energy economy and heat retention (BWR 6)

3.6.1 Thermal performance

The joint systems may increase heat loss (thermal bridging) in external elements and junctions. The heat loss associated with elements (*U-values*) and junctions (*ψ-values*) were determined in accordance with EN ISO 10211:2017 and are presented in Table 2 and Table 3.

Table 2: Thermal resistance of the slab (without R_{si} and R_{se})

Slab height (mm)	R_{slab} (m ² .K /W)
130	0.05
150	0.06
165	0.07
180	0.07
200	0.08
230	0.09
250	0.10
280	0.11
300	0.12

Table 3: ψ -values of the joints

Slab height (mm)	ψ -values (W/m)		
	ALPHA®	SINUSPROTECT®	M®
130	0.025	0.031	0.027
150	0.026	0.032	0.027
165	0.027	0.033	0.029
180	0.028	0.033	0.029
200	0.030	0.035	0.031
230	0.031	0.035	0.032
250	0.032	0.036	0.033
280	0.032	0.036	0.033
300	0.033	0.037	0.034

The lambda values considered in the calculation are presented in Table 4.

Table 4: Lambda values considered in the calculation

Material	λ (W/(m.K))
Reinforced concrete (2400 kg/m ³)	2.5
Steel (7800 kg/m ³)	50

3.6.2 Condensation risk

The joint systems may increase thermal bridging in external elements and junctions. If required, the risk of surface condensation for elements and junctions incorporating the systems must be determined by comparison of temperature factors, f_{Rsi} , (established in accordance with EN ISO 10211:2017) with the maximum temperature factor, $f_{Rsi,max}$ (established in accordance with EN ISO 13788:2012). Elements and/or junctions are acceptable when $f_{Rsi} > f_{Rsi,max}$. The temperature factor f_{Rsi} for the MGSI® joints is presented in Table 5.

Table 5: f_{Rsi} -values

Slab height (mm)	f_{Rsi} -values (W/°C.m)		
	ALPHA®	SINUSPROTECT®	M®
130	0.300	0.310	0.294
150	0.319	0.329	0.313
165	0.333	0.343	0.327
180	0.346	0.356	0.341
200	0.364	0.373	0.358
230	0.387	0.397	0.382
250	0.402	0.412	0.397
280	0.424	0.433	0.419
300	0.437	0.446	0.433

3.7 Sustainable use of natural resources (BWR 7)

Not relevant.

4. Assessment and verification of constancy of performance (hereinafter AVCP) system applied, with reference to its legal base

According to the Decision 1998/214/EC of European Commission as amended by the European Commission Decision 2001/596/EC, the system of assessment and verification of constancy of performance (see Annex V to Regulation (EU) No. 305/2011) is 2+.

5. Technical details necessary for the implementation of the AVCP system, as provided for in the applicable EAD

The ETA is issued on the basis of agreed data/information, deposited at Itecons, which identifies the product that has been assessed and judged. It is the manufacturer's responsibility to make sure that all those who use the construction product are appropriately informed of specific conditions laid down in this ETA.

Changes to the in-situ concrete slab permanent joint former or the components or their production process should be notified to the Itecons before the changes are introduced. Itecons will decide whether or not such changes affect the ETA and if so whether further assessment or alterations to the ETA shall be necessary.

Issued in Coimbra on 27.07.2023

By

Technical Assessment Unit of

Itecons – Instituto de Investigação e Desenvolvimento Tecnológico para a Construção, Energia, Ambiente e Sustentabilidade



Andreia Gil
Senior Official

(Technical Assessment Unit Coordinator)



Validated document

(Administration)

ANNEX A – TYPES of JOINT FORMERS

The details about the components of the joint former types are given in this section:

A1 – SINUSPROTECT MGSI®

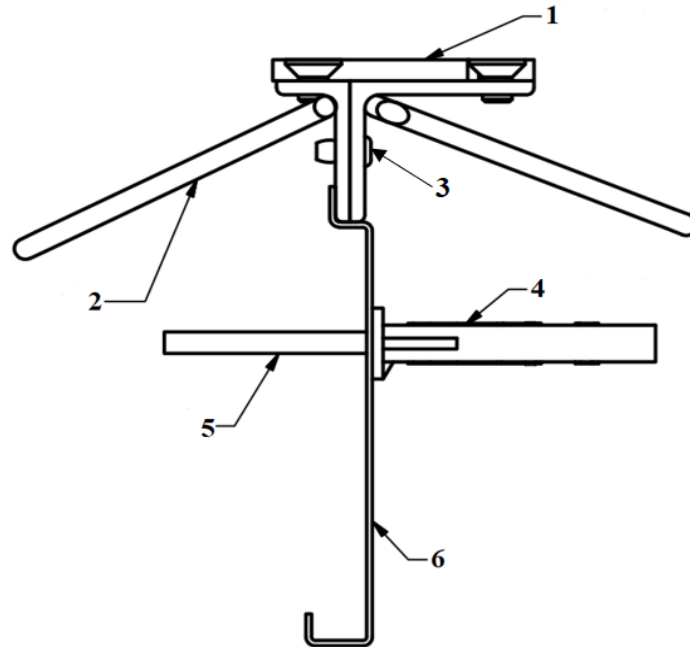

- | | |
|--|---|
| 1. Horizontal plate with a wave shaped split line; | 4. Dowel sleeve; |
| 2. Concrete anchorage; | 5. Dowel - load transmission mechanism; |
| 3. Fragile connection; | 6. Divider plate with fixed depth. |

Figure A1.1: SINUSPROTECT MGSI® cross section view – zigzag rod

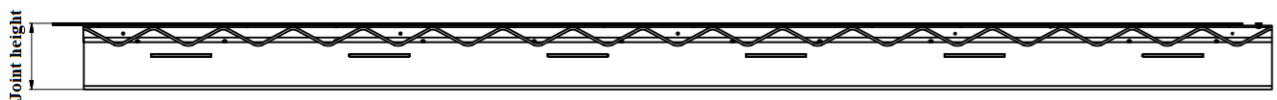

Figure A1.2: SINUSPROTECT MGSI® front view – zigzag rod

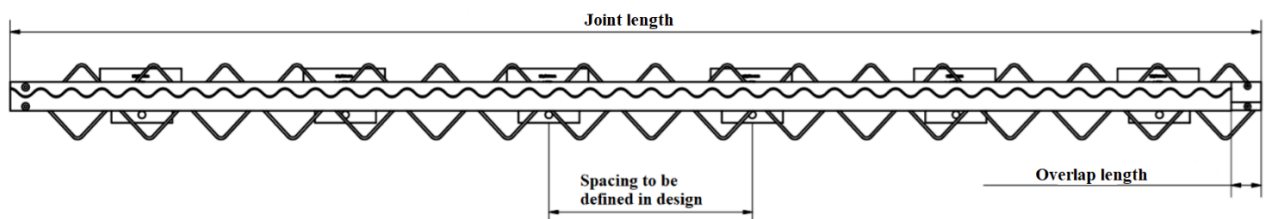
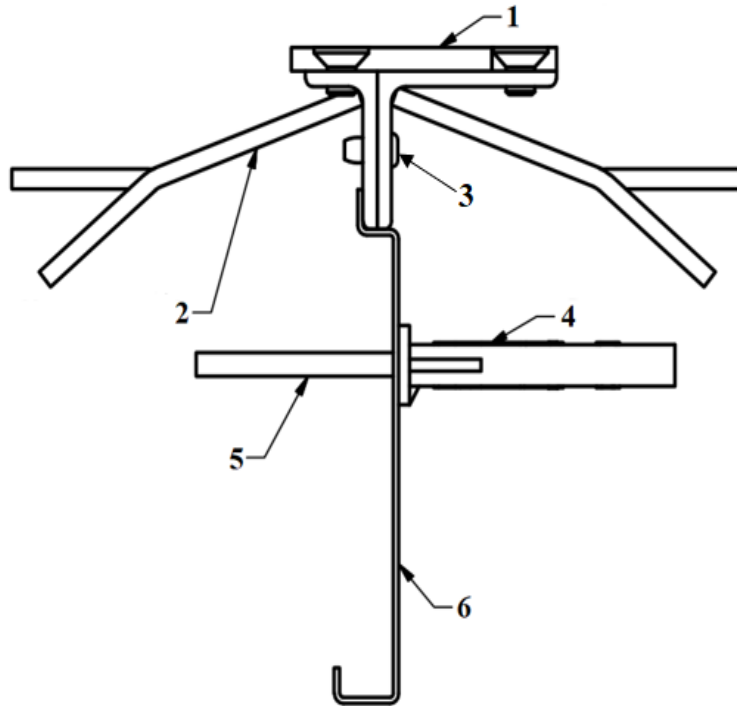

Figure A1.3: SINUSPROTECT MGSI® top view – zigzag rod



- | | |
|--|---|
| 1. Horizontal plate with a wave shaped split line; | 4. Dowel sleeve; |
| 2. Concrete anchorage; | 5. Dowel - load transmission mechanism; |
| 3. Fragile connection; | 6. Divider plate with fixed depth. |

Figure A1.4: SINUSPROTECT MGSI® cross section view – spikes

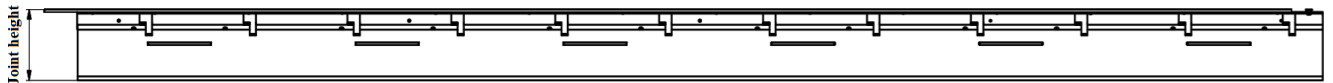

Figure A1.5: SINUSPROTECT MGSI® front view – spikes

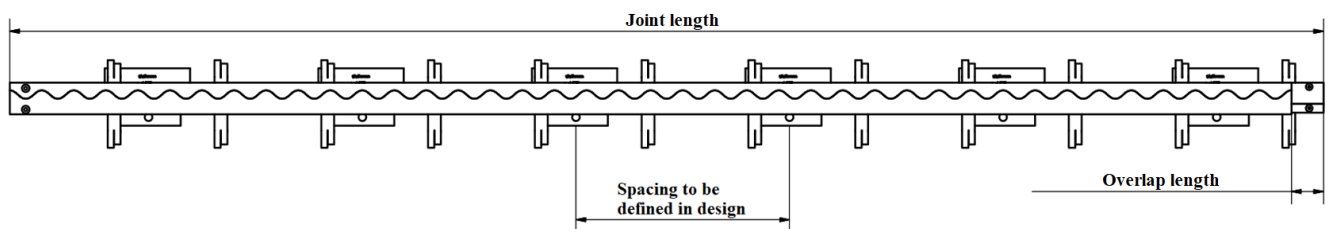
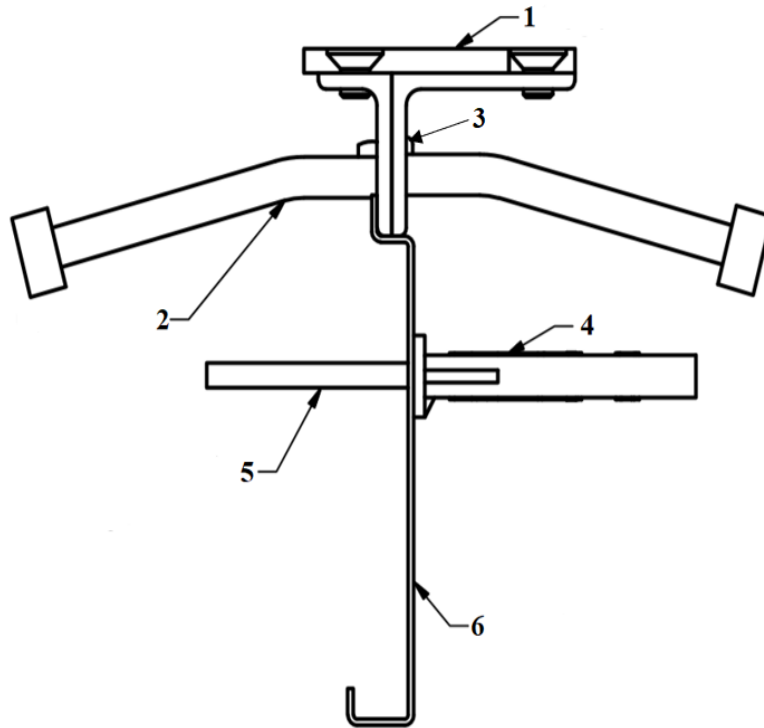

Figure A1.6: SINUSPROTECT MGSI® top view – spikes



- | | |
|--|---|
| 1. Horizontal plate with a wave shaped split line; | 4. Dowel sleeve; |
| 2. Concrete anchorage; | 5. Dowel - load transmission mechanism; |
| 3. Fragile connection; | 6. Divider plate with fixed depth. |

Figure A1.7: SINUSPROTECT MGSI® cross section view – shear studs

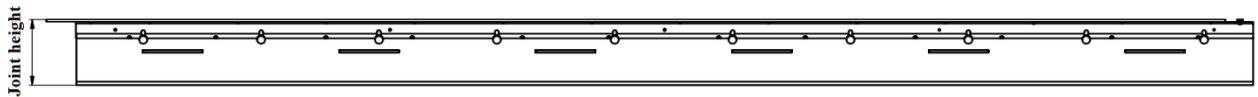

Figure A1.8: SINUSPROTECT MGSI® front view – shear studs

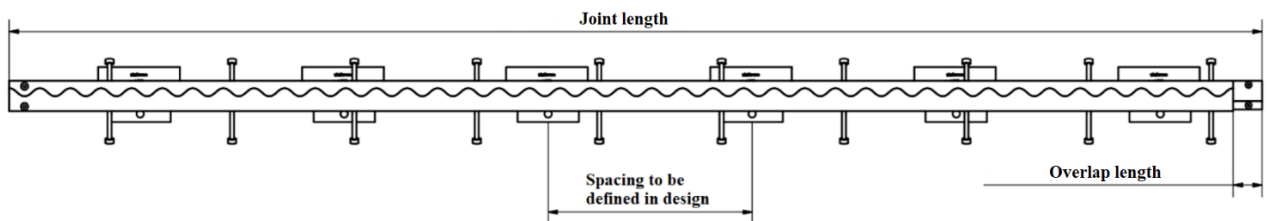
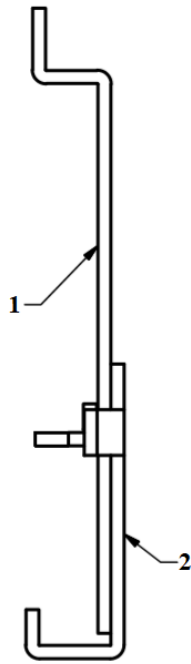

Figure A1.9: SINUSPROTECT MGSI® top view – shear studs



1. Upper plate

2. Lower plate

Figure A1.10: SINUSPROTECT MGSI® – cross section view of the divider plate with depth adjustment

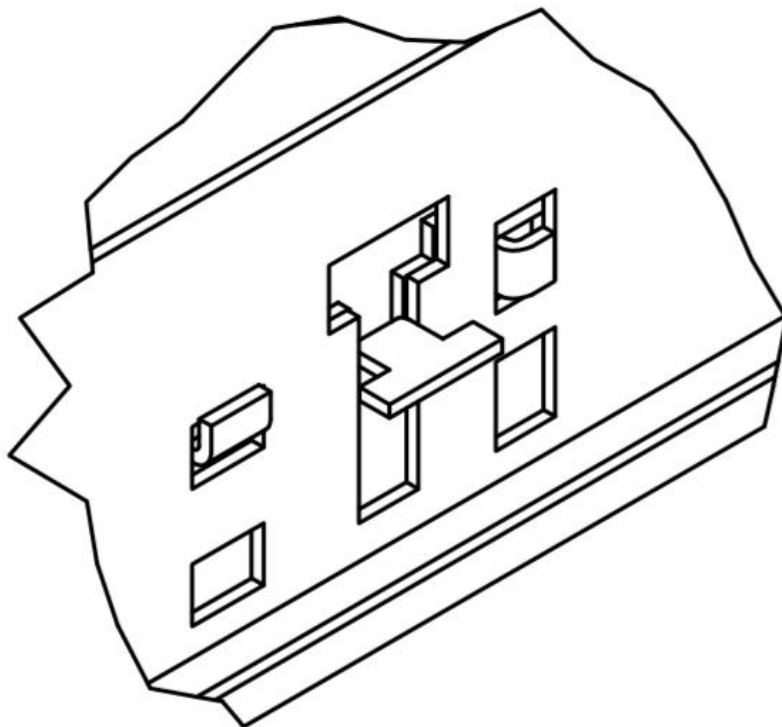

Figure A1.11: SINUSPROTECT MGSI® divider plate – detailed view of the upper and lower plate connection

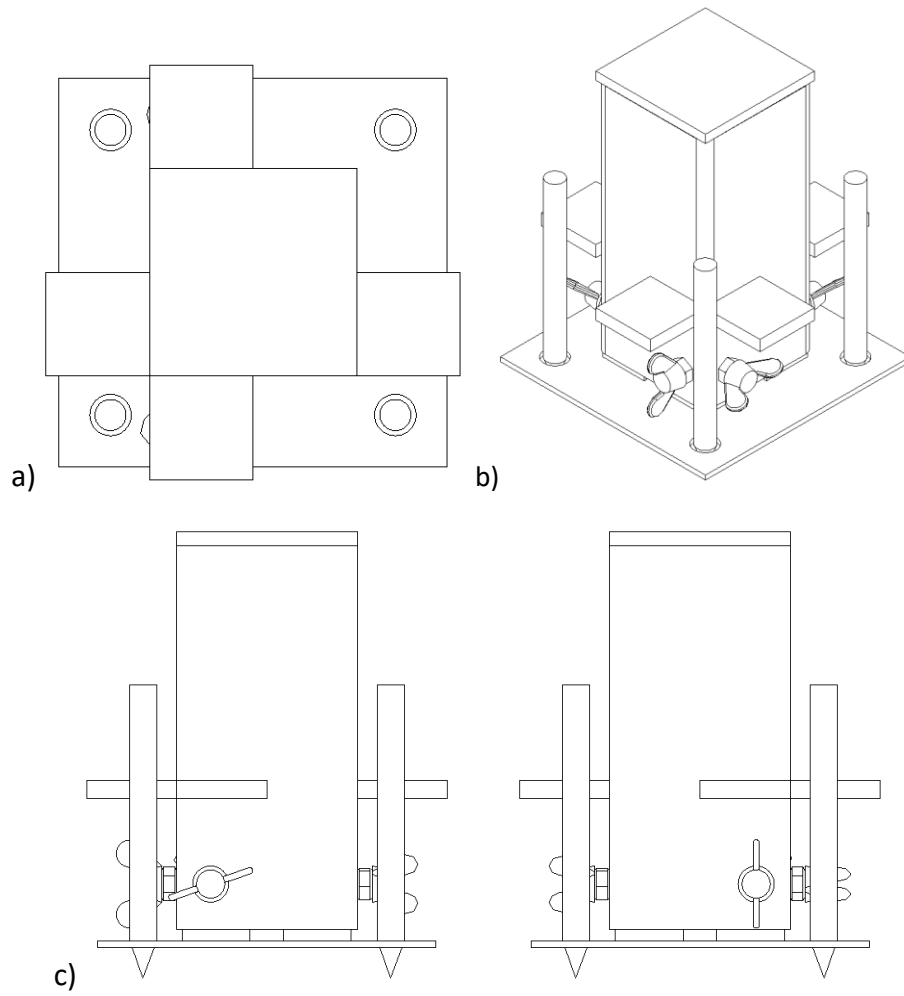
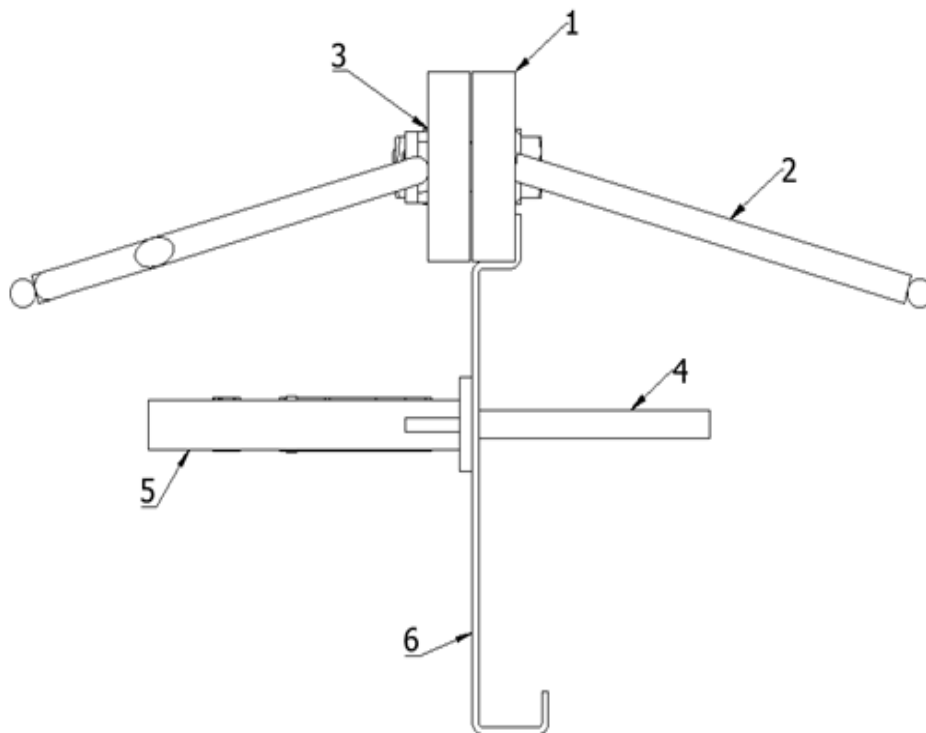

Figure A1.12: SINUSPROTECT MGSI® accessories: a) top plan view; b) Iso view and c) front view

A2 – ALPHA MGSI®



- | | |
|------------------------|--------------------------------------|
| 1. Solid steel strip; | 4. Dowel – Load transmission device; |
| 2. Concrete anchorage; | 5. Dowel sleeve; |
| 3. Fragile connection; | 6. Divider plate with fixed depth. |

Figure A2.1: ALPHA MGSI® cross section view – zigzag rod

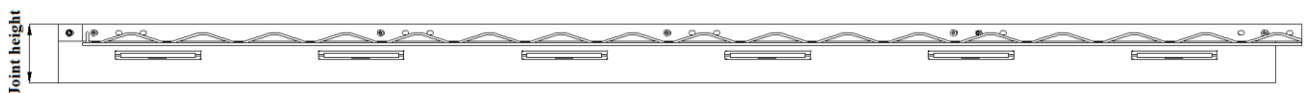

Figure A2.2: ALPHA MGSI® front view – zigzag rod

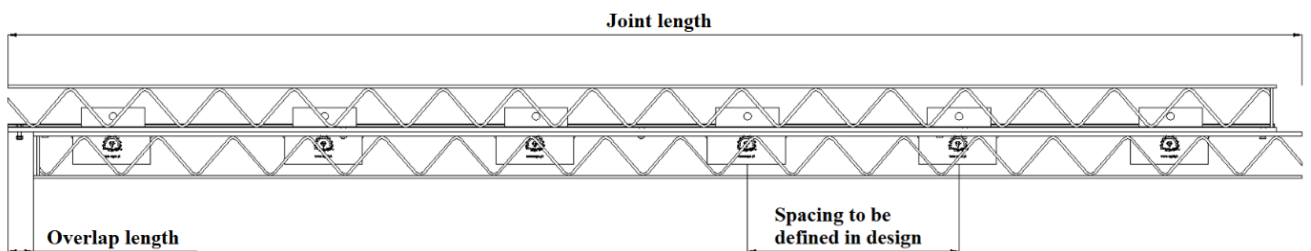
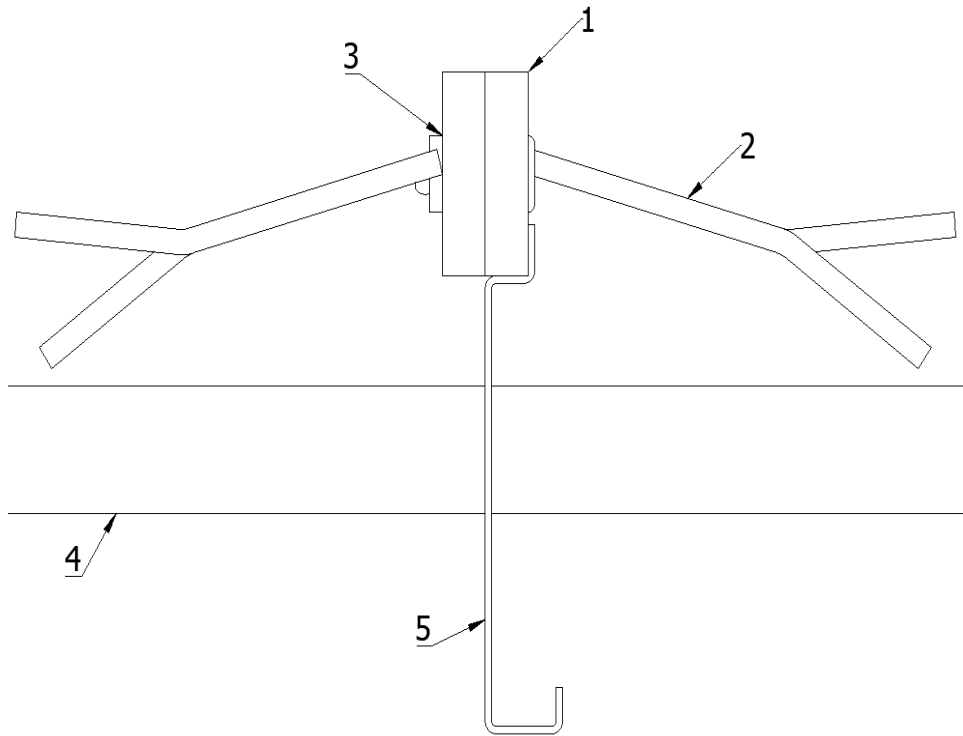

Figure A2.3: ALPHA MGSI® top view – zigzag rod



- | | |
|------------------------|--------------------------------------|
| 1. Solid steel strip; | 4. Dowel – Load transmission device; |
| 2. Concrete anchorage; | 5. Divider plate with fixed depth. |
| 3. Fragile connection; | |

Figure A2.4: ALPHA MGSI® cross section view – spikes

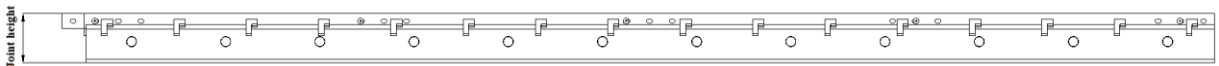

Figure A2.5: ALPHA MGSI® front view – spikes

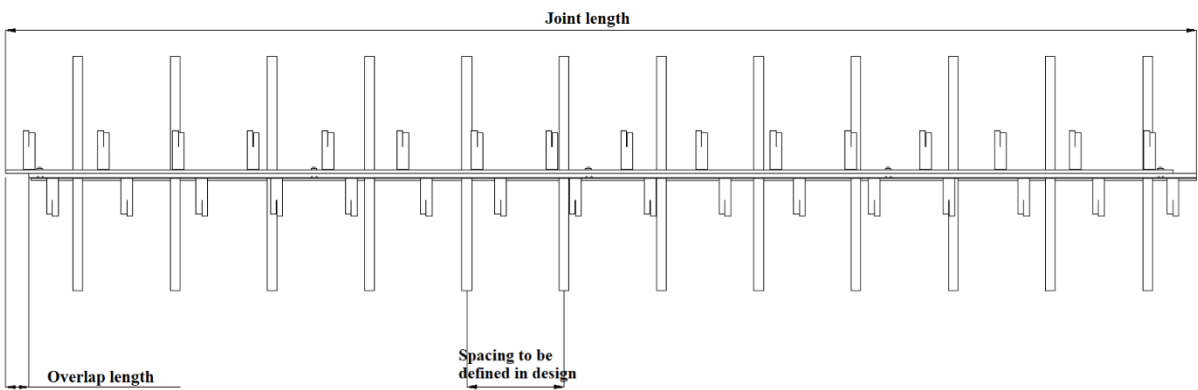
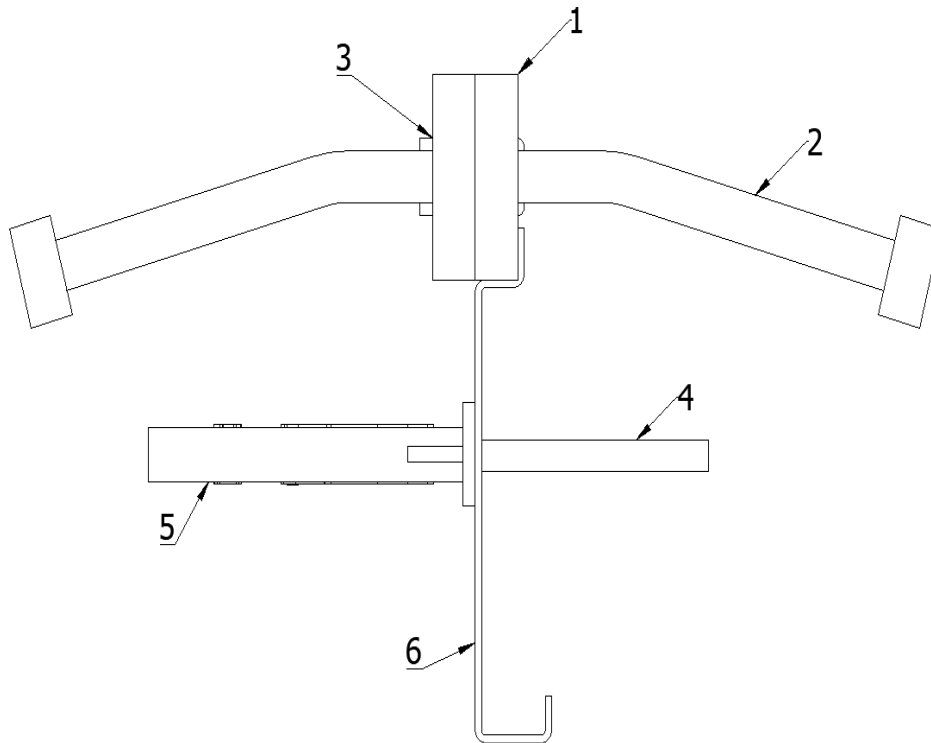

Figure A2.6: ALPHA MGSI® top view – spikes



- | | |
|------------------------|--------------------------------------|
| 1. Solid steel strip; | 4. Dowel – Load transmission device; |
| 2. Concrete anchorage; | 5. Dowel sleeve; |
| 3. Fragile connection; | 6. Divider plate with fixed depth. |

Figure A2.7: ALPHA MGSI® cross section view – shear studs

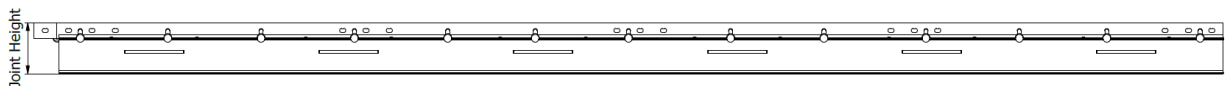

Figure A2.8: ALPHA MGSI® front view – shear studs

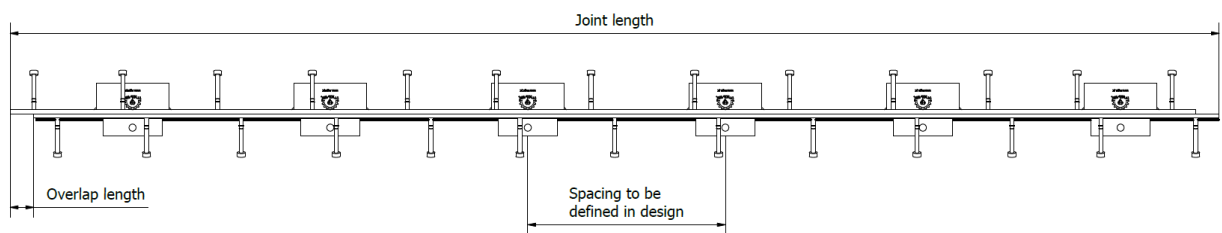
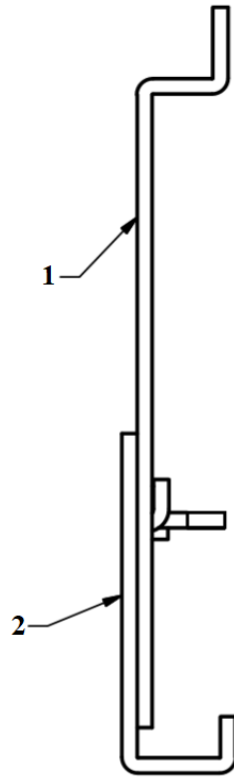

Figure A2.9: ALPHA MGSI® top view – shear studs



1. Upper plate

2. Lower plate

Figure A2.10: ALPHA MGSI® – cross section view of the divider plate with depth adjustment

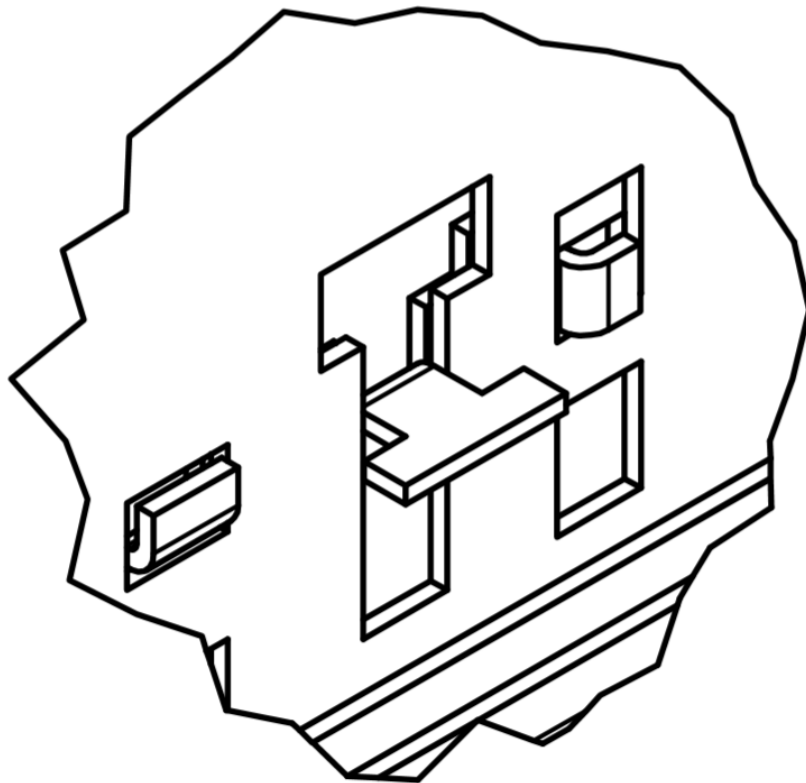

Figure A2.11: ALPHA MGSI® divider plate – detailed view of the upper and lower plate connection

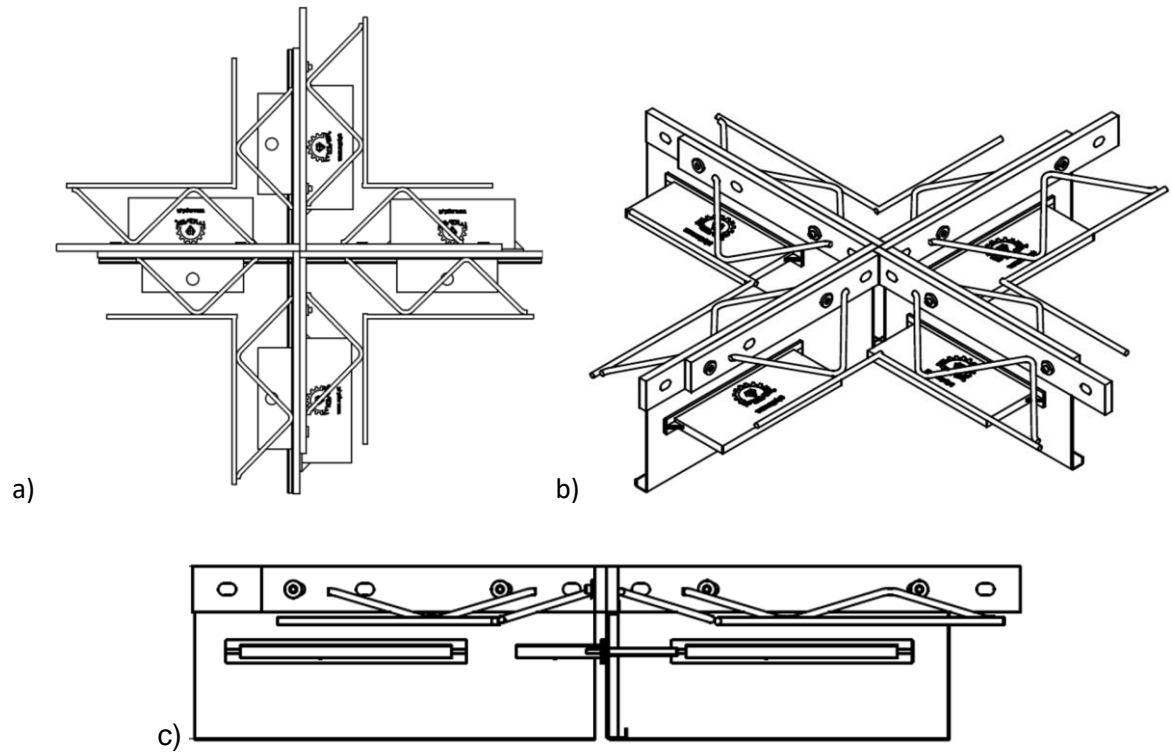

Figure A2.12: Example of ALPHA MGSI® X (four way) accessories – zigzag rod: a) top plan view; b) Iso view and c) front view

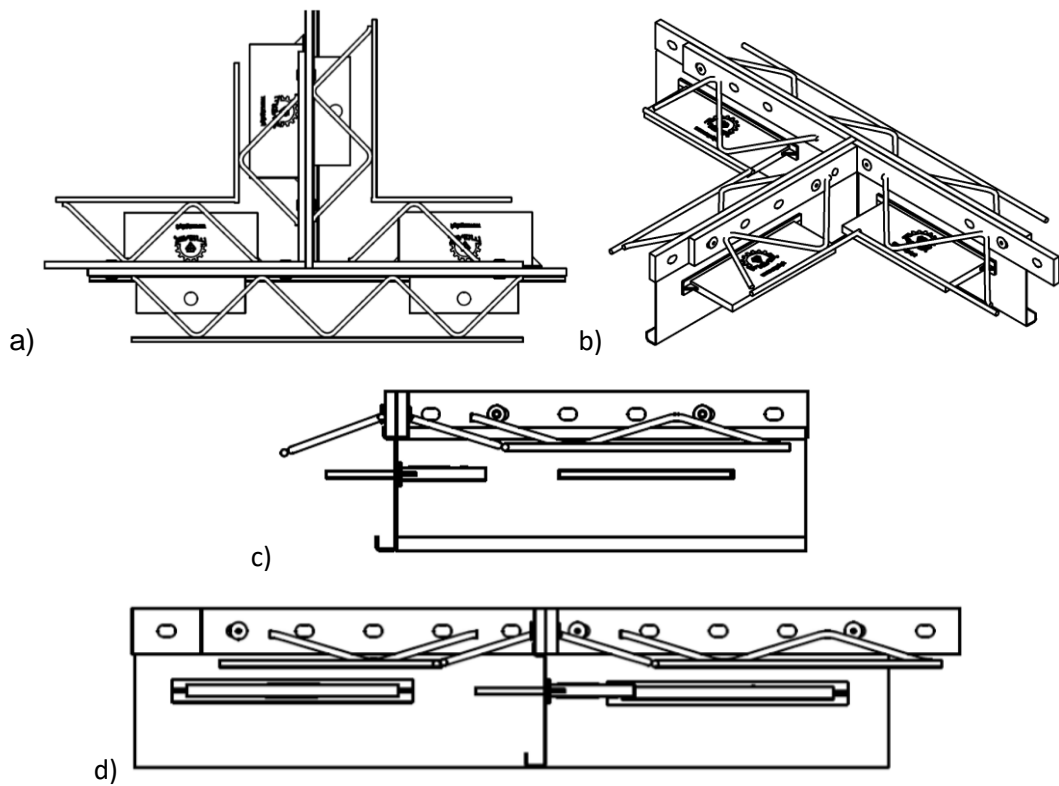

Figure A2.13: Example of ALPHA MGSI® T (tee) accessories – zigzag rod: a) top plan view; b) Iso view; c) front view 1 and d) front view 2

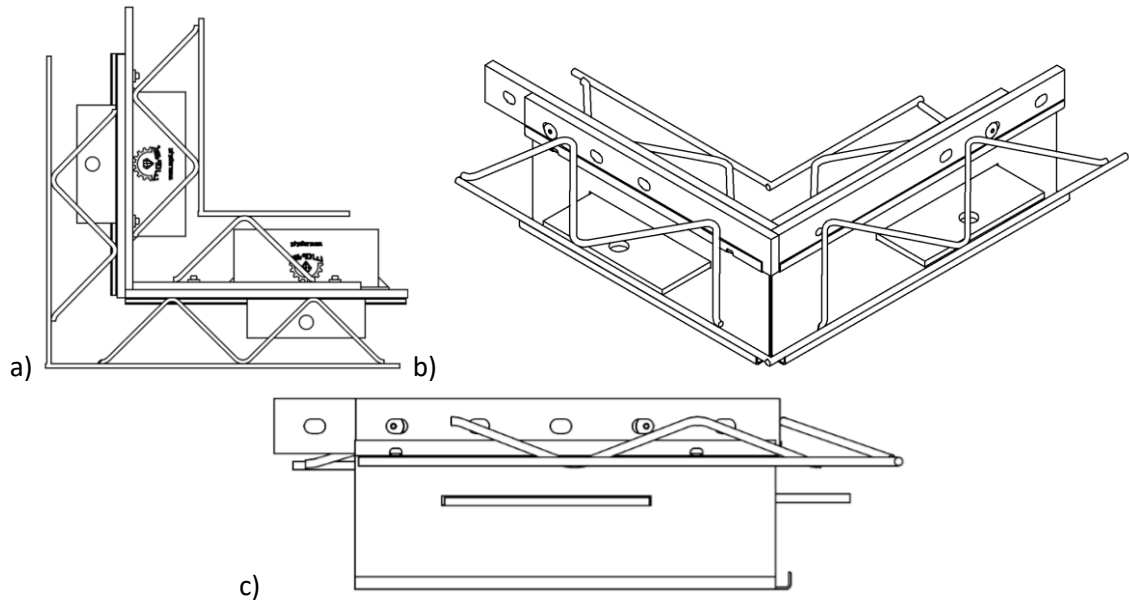
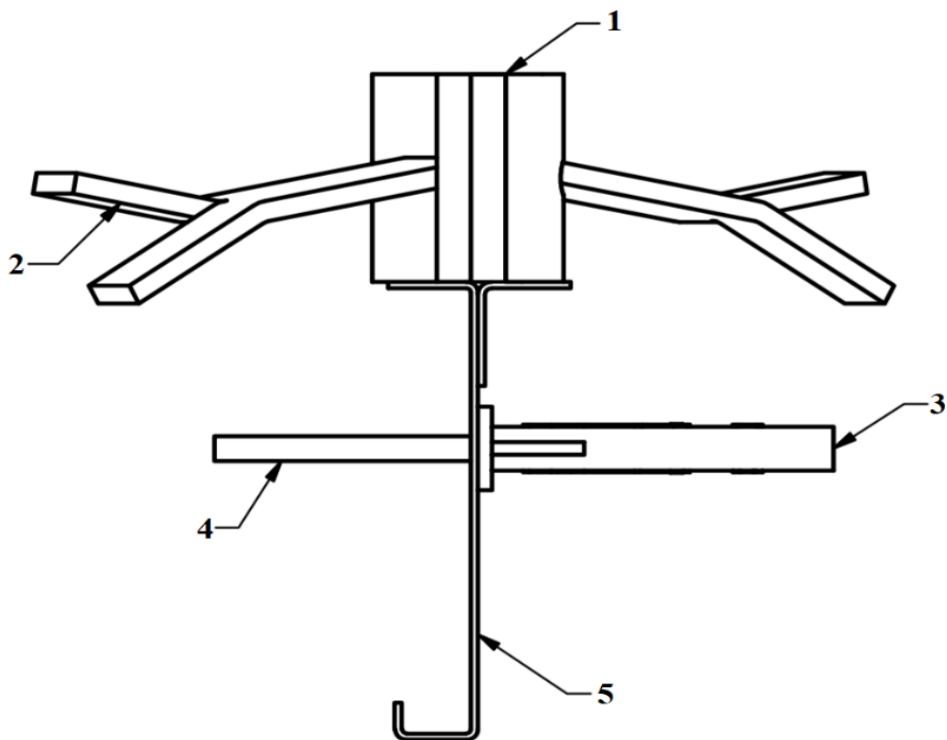

Figure A2.14: Example of ALPHA MGSI® L (corner) accessories – zigzag rod: a) top plan view; b) Iso view; c) front view

A3 – M-MGSI®



- | | |
|-------------------------------------|---|
| 1. Set of 2 saw-like shaped strips; | 4. Dowel – Load transmission mechanism; |
| 2. Concrete anchorage; | 5. Divider plate with fixed depth. |
| 3. Dowel sleeve; | |

Figure A3.1: M-MGSI® cross section view – spikes

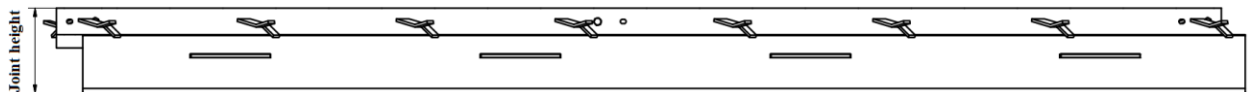

Figure A3.2: M-MGSI® front view – spikes

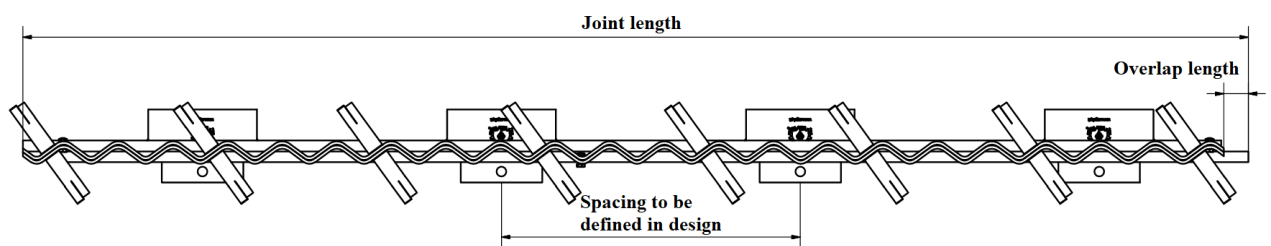
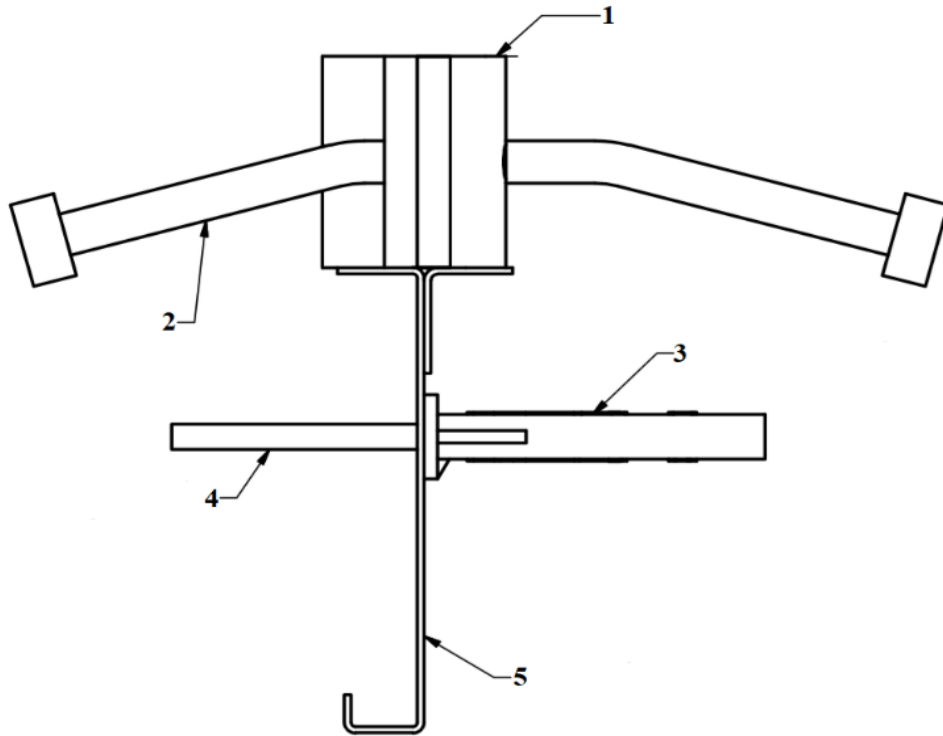

Figure A3.3: M-MGSI® top view – spikes



- | | |
|-------------------------------------|---|
| 1. Set of 2 saw-like shaped strips; | 4. Dowel – Load transmission mechanism; |
| 2. Concrete anchorage; | 5. Divider plate with fixed depth. |
| 3. Dowel sleeve; | |

Figure A3.4: M-MGSI® cross section view – shear studs

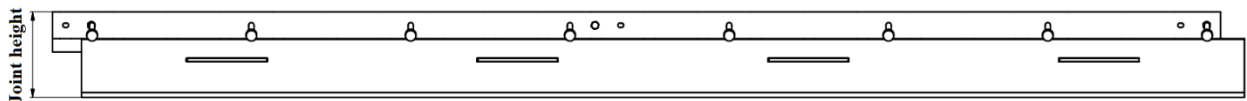

Figure A3.5: M-MGSI® front view – shear studs

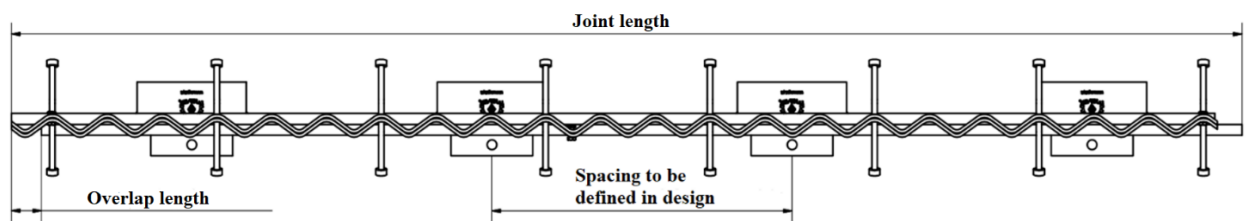
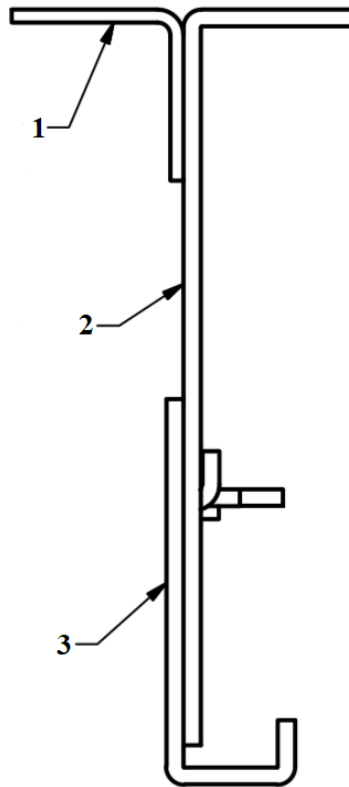

Figure A3.6: M-MGSI® top view – shear studs



- 1. Plate in "L" / angle bracket
- 2. Upper plate
- 3. Lower plate

Figure A3.7: M-MGSI® – cross section view of the divider plate with depth adjustment

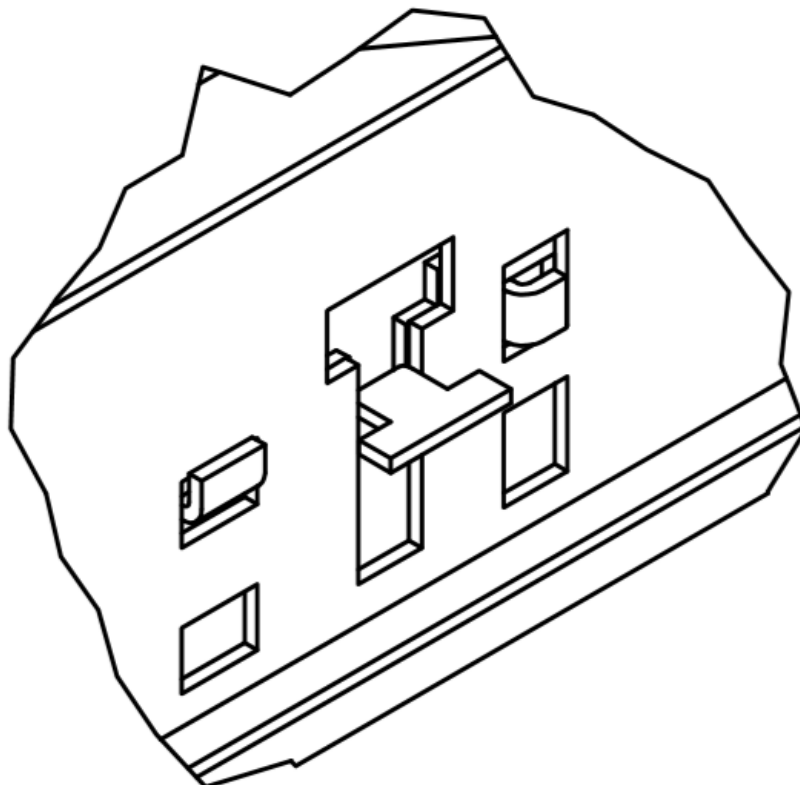

Figure A3.8: M-MGSI® divider plate – detailed view of the upper and lower plate connection

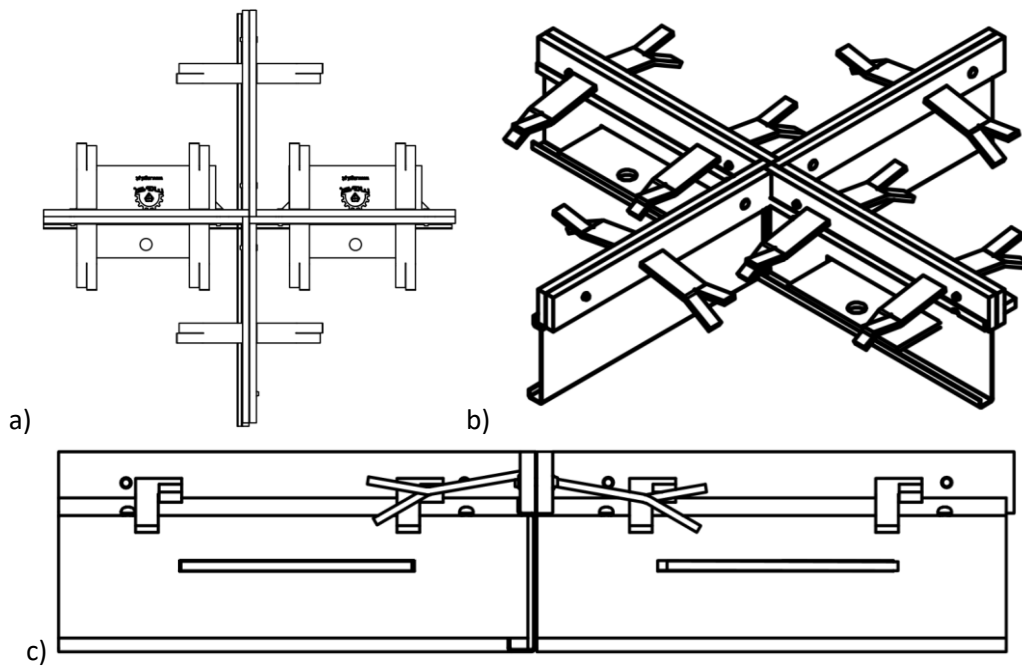

Figure A3.9: Example of M-MGSI® X (four way) accessories: a) top plan view; b) Iso view and c) front view

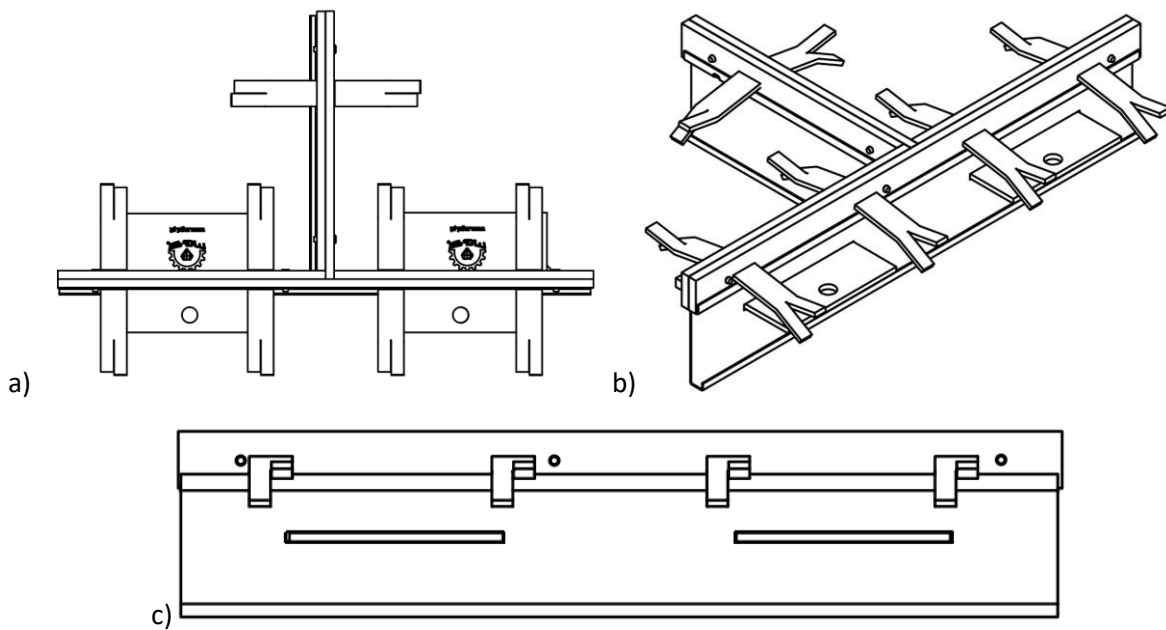

Figure A3.10: Example of M-MGSI® T (tee) accessories: a) top plan view; b) Iso view; c) front view

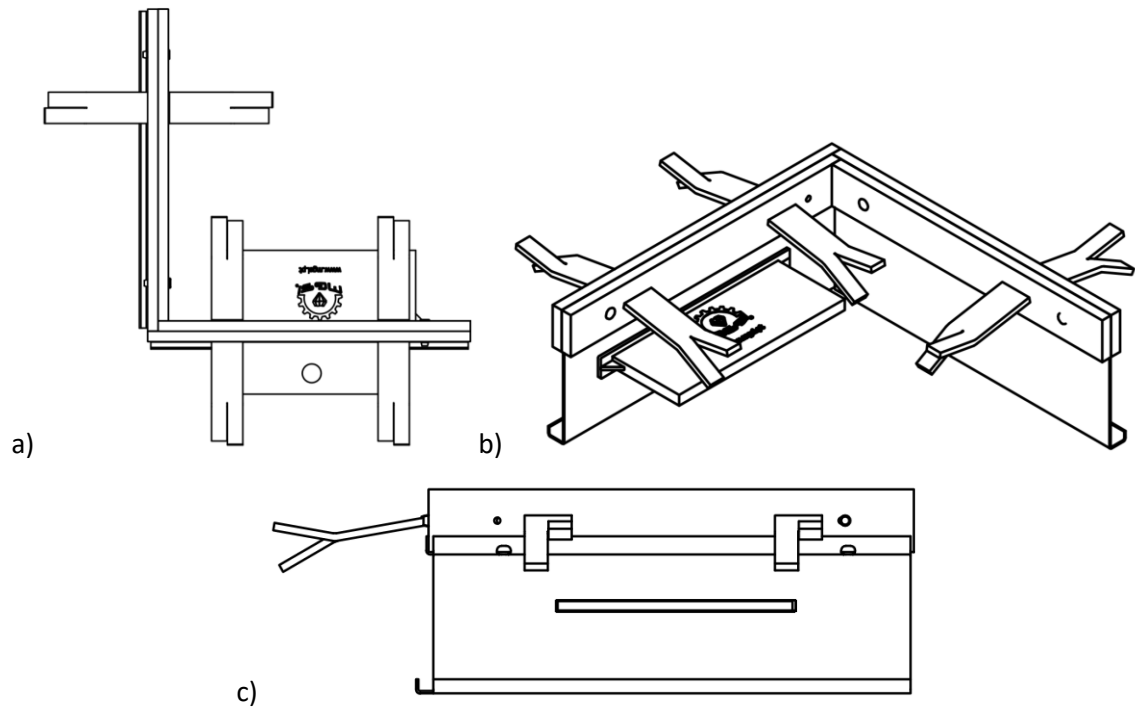

Figure A3.11: Example of M-MGSI® L (corner) accessories: a) top plan view; b) Iso view; c) front view

A4 – Accessory for joint intersection

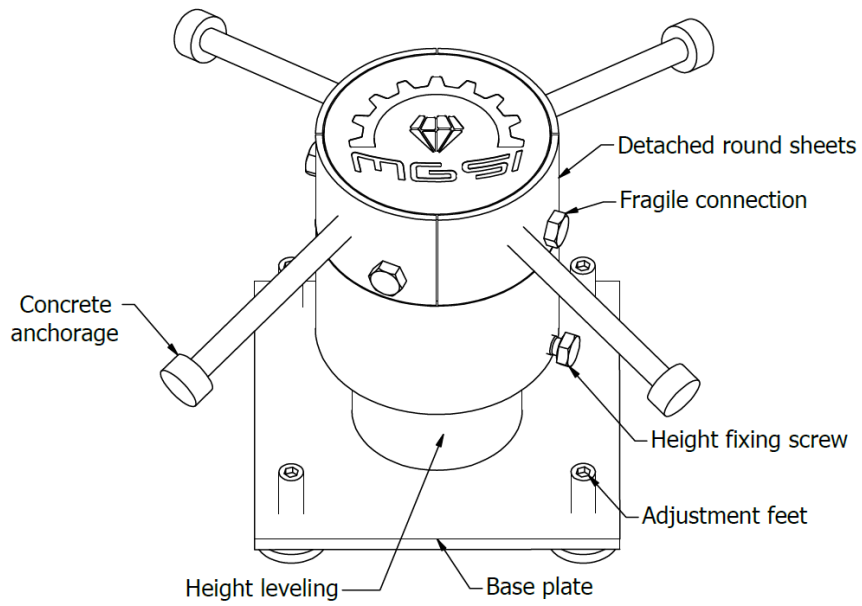

Figure A4.1: Accessory for joint intersection for all types of joints

A5 – Load Transmission Devices

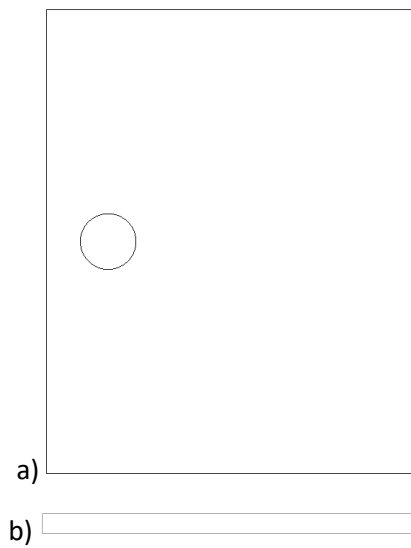

Figure A5.1: Dowel plate: a) top plan view; b) front and side view

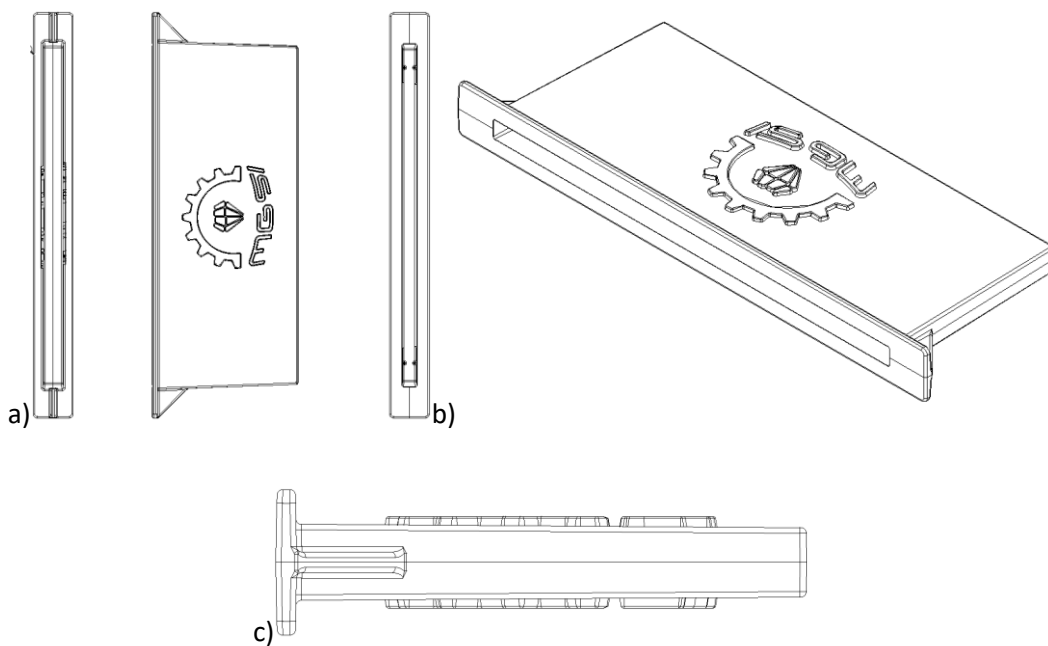

Figure A5.2: Dowel sleeve: a) front, back and top plan view; b) iso view; c) side view



Figure A5.3: Round dowel bar: top plan, side and front view

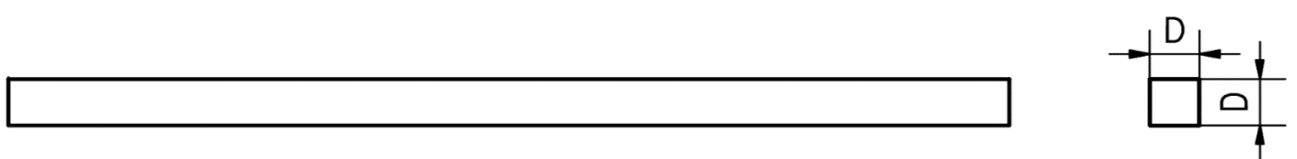

Figure A5.4: Square dowel bar: top plan, side and front view

ANNEX B – DOWEL LOAD TRANSFER

The methodology used for calculating the load transfer capacity of dowels was adopted from TR34, Fourth edition (2016), according to EAD 200089-00-0302. The dowels are classified to bar dowels and plate dowels, and the calculation method is presented for each separately.

B.1 Conventional bar dowels

Dowels in accordance with EN 13877-3:2004 are short lengths of smooth steel of either round, square or rectangular section used at joints to enable loads to be transferred from one side of the joint to the other with no significant differential deflection.

The shear capacity is given by:

$$P_{sh\ dowel} = 0.6f_{yd}A_v \quad \text{Equation 1}$$

Where: $f_{yd} = f_{yk}/\gamma_s$ = design yield strength of dowel

A_v = Shear Area of taken as 0.9 x area of the dowel section

f_{yk} = yield strength of dowel

γ_s = partial safety factor for steel, taken as 1.15

The calculated values for $P_{sh\ dowel}$ using Equation 1 are presented in Table B1.1 and Table B1.2.

Table B1.1: calculated values for $P_{sh\ dowel}$

Bar dowel type	Diameter (mm)	f_{yk} (MPa)	γ_s	A_v (mm ²)	$P_{sh\ dowel}$ (N)
Round	16	275	1.15	201.1 x 0.9	25.96
		355			33.52
		460			43.43
	20	275	1.15	314.2 x 0.9	40.57
		355			52.37
		460			67.86
	22	275	1.15	380.1 x 0.9	49.09
		355			63.37
		460			82.11
	25	275	1.15	490.9 x 0.9	63.39
		355			81.83
		460			106.03
	32	275	1.15	804.2 x 0.9	103.85
		355			134.06
		460			173.72
40	275	1.15	1256.6 x 0.9	162.27	
	355			209.48	
	460			271.43	

Table B1.2: calculated values for $P_{sh\ dowel}$

Bar dowel type	Width (mm)	Thickness (mm)	f_{yk} (MPa)	γ_s	A_v (mm ²)	$P_{sh\ dowel}$ (kN)
Square	16	16	275	1.15	0.9 x 256.0	33.06
			355			42.67
			460			55.30
	20	20	275	1.15	0.9 x 400.0	51.65
			355			66.68
			460			86.40
	25	25	275	1.15	0.9 x 625.0	80.71
			355			104.18
			460			135.00
	30	30	275	1.15	0.9 x 900.0	116.22
			355			150.03
			460			194.40
	32	32	275	1.15	0.9 x 1024.0	132.23
			355			170.70
			460			221.18
	40	40	275	1.15	0.9 x 1600.0	206.61
			355			266.71
			460			345.60

The bearing/bending capacity per dowel, P_{bear} , is given by:

$$P_{max\ dowel} = d_d^2 (f_{cd} f_{yd})^{0.5} [(1 + \alpha^2)^{0.5} - \alpha] \quad \text{Equation 2}$$

Where: d_d = diameter of round dowel or width of square bar

$$f_{cd} = f_{ck} / \gamma_c = \text{concrete design compressive cylinder strength}$$

$$f_{yd} = f_{yk} / \gamma_s = \text{characteristic strength of steel dowel}$$

$$\alpha = 3e [(f_{cd} / f_{yd})^{0.5}] / d_d$$

e = half of joint opening width

γ_c = partial safety factor for concrete, taken as 1.50

The calculated values for $P_{max, dowel}$ using Equation 2 are presented in Tables B1.3 to Table B1.13.

Table B1.3: Calculated values for D16 – $P_{max,dowel}$

D16 – $P_{max,dowel}$ [kN]						
Steel	Concrete	Joint opening (mm)				
		5	10	15	20	30
S275	C20/25	12.94	11.61	10.43	9.41	7.75
	C25/30	14.28	12.65	11.24	10.03	8.13
	C30/37	15.47	13.54	11.91	10.54	8.42
	C32/40	15.90	13.87	12.15	10.72	8.52
	C35/40	16.53	14.33	12.49	10.96	8.65
	C40/50	17.49	15.02	12.98	11.32	8.85
S355	C20/25	14.90	13.53	12.31	11.23	9.42
	C25/30	16.47	14.79	13.32	12.03	9.94
	C30/37	17.86	15.88	14.16	12.69	10.34
	C32/40	18.37	16.28	14.47	12.92	10.48
	C35/40	19.11	16.84	14.89	13.24	10.66
	C40/50	20.25	17.69	15.53	13.72	10.94
S460	C20/25	17.16	15.77	14.50	13.36	11.42
	C25/30	19.00	17.28	15.75	14.38	12.10
	C30/37	20.62	18.60	16.80	15.23	12.65
	C32/40	21.23	19.08	17.18	15.53	12.84
	C35/40	22.09	19.76	17.72	15.95	13.10
	C40/50	23.43	20.80	18.53	16.58	13.48

Table B1.4: Calculated values for D20 – $P_{max,dowel}$

D20 – $P_{max,dowel}$ [kN]						
Steel	Concrete	Joint opening (mm)				
		5	10	15	20	30
S275	C20/25	20.67	18.94	17.37	15.96	13.58
	C25/30	22.88	20.74	18.84	17.16	14.37
	C30/37	24.82	22.31	20.09	18.15	15.00
	C32/40	25.55	22.88	20.54	18.51	15.22
	C35/40	26.58	23.69	21.17	19.00	15.52
	C40/50	28.19	24.93	22.12	19.73	15.95
S355	C20/25	23.74	21.97	20.35	18.88	16.33
	C25/30	26.30	24.12	22.16	20.38	17.38
	C30/37	28.57	26.00	23.69	21.64	18.22
	C32/40	29.42	26.69	24.25	22.09	18.51
	C35/40	30.63	27.66	25.03	22.72	18.92
	C40/50	32.51	29.16	26.22	23.66	19.51
S460	C20/25	27.28	25.48	23.82	22.29	19.58
	C25/30	30.26	28.04	26.01	24.16	20.94
	C30/37	32.90	30.28	27.89	25.74	22.05
	C32/40	33.89	31.10	28.58	26.30	22.44
	C35/40	35.30	32.27	29.54	27.10	22.98
	C40/50	37.51	34.08	31.02	28.30	23.78

Table B1.5: Calculated values for D22 – $P_{max,dowel}$

D22 – $P_{max,dowel}$ [kN]						
Steel	Concrete	Joint opening (mm)				
		5	10	15	20	30
S275	C20/25	25.22	23.28	21.52	19.91	17.15
	C25/30	27.93	25.55	23.40	21.48	18.23
	C30/37	30.33	27.52	25.01	22.78	19.09
	C32/40	31.23	28.24	25.59	23.25	19.39
	C35/40	32.51	29.26	26.40	23.90	19.80
	C40/50	34.50	30.84	27.64	24.87	20.41
S355	C20/25	28.93	26.96	25.14	23.47	20.54
	C25/30	32.08	29.65	27.43	25.42	21.94
	C30/37	34.87	32.00	29.40	27.06	23.08
	C32/40	35.91	32.86	30.11	27.64	23.48
	C35/40	37.41	34.09	31.12	28.47	24.03
	C40/50	39.73	35.99	32.65	29.71	24.84
S460	C20/25	33.21	31.22	29.36	27.63	24.53
	C25/30	36.86	34.40	32.12	30.02	26.32
	C30/37	40.12	37.19	34.51	32.06	27.80
	C32/40	41.33	38.22	35.38	32.79	28.33
	C35/40	43.07	39.69	36.61	33.83	29.05
	C40/50	45.78	41.96	38.50	35.40	30.13

Table B1.6: Calculated values for D25 – $P_{max,dowel}$

D25 – $P_{max,dowel}$ [kN]						
Steel	Concrete	Joint opening (mm)				
		5	10	15	20	30
S275	C20/25	32.88	30.64	28.58	26.68	23.35
	C25/30	36.46	33.70	31.18	28.89	24.94
	C30/37	39.64	36.37	33.41	30.75	26.23
	C32/40	40.82	37.35	34.23	31.42	26.68
	C35/40	42.52	38.75	35.37	32.36	27.31
	C40/50	45.16	40.90	37.11	33.77	28.23
S355	C20/25	37.68	35.41	33.29	31.33	27.81
	C25/30	41.81	39.01	36.42	34.04	29.84
	C30/37	45.50	42.18	39.13	36.35	31.52
	C32/40	46.88	43.35	40.12	37.18	32.11
	C35/40	48.85	45.01	41.52	38.36	32.93
	C40/50	51.93	47.58	43.66	40.13	34.15
S460	C20/25	43.21	40.92	38.76	36.73	33.05
	C25/30	48.00	45.16	42.51	40.04	35.62
	C30/37	52.28	48.90	45.77	42.88	37.76
	C32/40	53.87	50.29	46.97	43.91	38.52
	C35/40	56.16	52.26	48.67	45.37	39.59
	C40/50	59.74	55.32	51.27	47.58	41.18

Table B1.7: Calculated values for D32 – $P_{max,dowel}$

D32 – $P_{max,dowel}$ [kN]						
Steel	Concrete	Joint opening (mm)				
		5	10	15	20	30
S275	C20/25	54.71	51.77	49.01	46.42	41.73
	C25/30	60.77	57.14	53.75	50.60	44.96
	C30/37	66.18	61.86	57.87	54.17	47.65
	C32/40	68.20	63.61	59.37	55.47	48.61
	C35/40	71.09	66.11	61.51	57.30	49.94
	C40/50	75.62	69.97	64.80	60.09	51.94
S355	C20/25	62.57	59.61	56.79	54.13	49.24
	C25/30	69.56	65.88	62.42	59.17	53.27
	C30/37	75.80	71.43	67.34	63.52	56.66
	C32/40	78.14	73.49	69.15	65.11	57.88
	C35/40	81.49	76.43	71.72	67.35	59.58
	C40/50	86.73	80.98	75.67	70.77	62.13
S460	C20/25	71.65	68.66	65.80	63.07	58.01
	C25/30	79.70	75.99	72.47	69.13	62.99
	C30/37	86.92	82.49	78.31	74.38	67.21
	C32/40	89.61	84.91	80.47	76.30	68.74
	C35/40	93.49	88.36	83.54	79.03	70.88
	C40/50	99.55	93.73	88.29	83.21	74.11

Table B1.8: Calculated values for D40 – $P_{max\ dowel}$

D40 – $P_{max,dowel}$ [kN]						
Steel	Concrete	Joint opening (mm)				
		5	10	15	20	30
S275	C20/25	86.43	82.70	79.14	75.75	69.48
	C25/30	96.13	91.50	87.12	82.97	75.37
	C30/37	104.81	99.30	94.10	89.22	80.36
	C32/40	108.06	102.19	96.68	91.51	82.16
	C35/40	112.72	106.33	100.35	94.75	84.68
	C40/50	120.02	112.77	106.00	99.71	88.49
S355	C20/25	98.73	94.96	91.35	87.89	81.42
	C25/30	109.87	105.20	100.74	96.49	88.62
	C30/37	119.86	114.29	109.00	103.99	94.77
	C32/40	123.60	117.67	112.05	106.74	97.00
	C35/40	128.97	122.51	116.41	110.65	100.14
	C40/50	137.39	130.05	123.14	116.65	104.90
S460	C20/25	112.92	109.12	105.46	101.94	95.29
	C25/30	125.74	121.02	116.50	112.16	104.04
	C30/37	137.23	131.61	126.24	121.11	111.57
	C32/40	141.54	135.55	129.84	124.40	114.31
	C35/40	147.73	141.21	134.99	129.09	118.18
	C40/50	157.44	150.02	142.98	136.32	124.08

Table B1.9: Calculated values for S16 – $P_{max,dowel}$

S16 – $P_{max,dowel}$ [kN]						
Steel	Concrete	Joint opening (mm)				
		5	10	15	20	30
S275	C20/25	12.94	11.61	10.43	9.41	7.75
	C25/30	14.28	12.65	11.24	10.03	8.13
	C30/37	15.47	13.54	11.91	10.54	8.42
	C32/40	15.90	13.87	12.15	10.72	8.52
	C35/40	16.53	14.33	12.49	10.96	8.65
	C40/50	17.49	15.02	12.98	11.32	8.85
S355	C20/25	14.90	13.53	12.31	11.23	9.42
	C25/30	16.47	14.79	13.32	12.03	9.94
	C30/37	17.86	15.88	14.16	12.69	10.34
	C32/40	18.37	16.28	14.47	12.92	10.48
	C35/40	19.11	16.84	14.89	13.24	10.66
	C40/50	20.25	17.69	15.53	13.72	10.94
S460	C20/25	17.16	15.77	14.50	13.36	11.42
	C25/30	19.00	17.28	15.75	14.38	12.10
	C30/37	20.62	18.60	16.80	15.23	12.65
	C32/40	21.23	19.08	17.18	15.53	12.84
	C35/40	22.09	19.76	17.72	15.95	13.10
	C40/50	23.43	20.80	18.53	16.58	13.48

Table B1.10: Calculated values for S20 – $P_{max,dowel}$

S20 – $P_{max,dowel}$ [kN]						
Steel	Concrete	Joint opening (mm)				
		5	10	15	20	30
S275	C20/25	20.67	18.94	17.37	15.96	13.58
	C25/30	22.88	20.74	18.84	17.16	14.37
	C30/37	24.82	22.31	20.09	18.15	15.00
	C32/40	25.55	22.88	20.54	18.51	15.22
	C35/40	26.58	23.69	21.17	19.00	15.52
	C40/50	28.19	24.93	22.12	19.73	15.95
S355	C20/25	23.74	21.97	20.35	18.88	16.33
	C25/30	26.30	24.12	22.16	20.38	17.38
	C30/37	28.57	26.00	23.69	21.64	18.22
	C32/40	29.42	26.69	24.25	22.09	18.51
	C35/40	30.63	27.66	25.03	22.72	18.92
	C40/50	32.51	29.16	26.22	23.66	19.51
S460	C20/25	27.28	25.48	23.82	22.29	19.58
	C25/30	30.26	28.04	26.01	24.16	20.94
	C30/37	32.90	30.28	27.89	25.74	22.05
	C32/40	33.89	31.10	28.58	26.30	22.44
	C35/40	35.30	32.27	29.54	27.10	22.98
	C40/50	37.51	34.08	31.02	28.30	23.78

Table B1.11: Calculated values for S25 – $P_{max,dowel}$

S25 – $P_{max,dowel}$ [kN]						
Steel	Concrete	Joint opening (mm)				
		5	10	15	20	30
S275	C20/25	32.88	30.64	28.58	26.68	23.35
	C25/30	36.46	33.70	31.18	28.89	24.94
	C30/37	39.64	36.37	33.41	30.75	26.23
	C32/40	40.82	37.35	34.23	31.42	26.68
	C35/40	42.52	38.75	35.37	32.36	27.31
	C40/50	45.16	40.90	37.11	33.77	28.23
S355	C20/25	37.68	35.41	33.29	31.33	27.81
	C25/30	41.81	39.01	36.42	34.04	29.84
	C30/37	45.50	42.18	39.13	36.35	31.52
	C32/40	46.88	43.35	40.12	37.18	32.11
	C35/40	48.85	45.01	41.52	38.36	32.93
	C40/50	51.93	47.58	43.66	40.13	34.15
S460	C20/25	43.21	40.92	38.76	36.73	33.05
	C25/30	48.00	45.16	42.51	40.04	35.62
	C30/37	52.28	48.90	45.77	42.88	37.76
	C32/40	53.87	50.29	46.97	43.91	38.52
	C35/40	56.16	52.26	48.67	45.37	39.59
	C40/50	59.74	55.32	51.27	47.58	41.18

Table B1.12: Calculated values for S30 – $P_{max,dowel}$

S30 – $P_{max,dowel}$ [kN]						
Steel	Concrete	Joint opening (mm)				
		5	10	15	20	30
S275	C20/25	47.91	45.17	42.61	40.22	35.91
	C25/30	53.19	49.81	46.67	43.76	38.61
	C30/37	57.90	53.89	50.19	46.79	40.84
	C32/40	59.66	55.39	51.48	47.89	41.64
	C35/40	62.18	57.54	53.30	49.43	42.74
	C40/50	66.12	60.86	56.09	51.77	44.38
S355	C20/25	54.82	52.05	49.44	46.97	42.48
	C25/30	60.91	57.49	54.28	51.28	45.86
	C30/37	66.36	62.29	58.49	54.97	48.70
	C32/40	68.39	64.06	60.04	56.32	49.71
	C35/40	71.31	66.60	62.24	58.22	51.12
	C40/50	75.88	70.53	65.62	61.11	53.24
S460	C20/25	62.80	60.00	57.34	54.81	50.15
	C25/30	69.83	66.37	63.09	60.00	54.35
	C30/37	76.12	72.00	68.12	64.49	57.91
	C32/40	78.48	74.09	69.98	66.13	59.19
	C35/40	81.86	77.08	72.61	68.45	60.98
	C40/50	87.15	81.72	76.68	72.00	63.68

Table B1.13: Calculated values for S32 – $P_{max,dowel}$

S32 – $P_{max,dowel}$ [kN]						
Steel	Concrete	Joint opening (mm)				
		5	10	15	20	30
S275	C20/25	54.71	51.77	49.01	46.42	41.73
	C25/30	60.77	57.14	53.75	50.60	44.96
	C30/37	66.18	61.86	57.87	54.17	47.65
	C32/40	68.20	63.61	59.37	55.47	48.61
	C35/40	71.09	66.11	61.51	57.30	49.94
	C40/50	75.62	69.97	64.80	60.09	51.94
S355	C20/25	62.57	59.61	56.79	54.13	49.24
	C25/30	69.56	65.88	62.42	59.17	53.27
	C30/37	75.80	71.43	67.34	63.52	56.66
	C32/40	78.14	73.49	69.15	65.11	57.88
	C35/40	81.49	76.43	71.72	67.35	59.58
	C40/50	86.73	80.98	75.67	70.77	62.13
S460	C20/25	71.65	68.66	65.80	63.07	58.01
	C25/30	79.70	75.99	72.47	69.13	62.99
	C30/37	86.92	82.49	78.31	74.38	67.21
	C32/40	89.61	84.91	80.47	76.30	68.74
	C35/40	93.49	88.36	83.54	79.03	70.88
	C40/50	99.55	93.73	88.29	83.21	74.11

Table B1.14: Calculated values for S40 – $P_{max,dowel}$

S40 – $P_{max,dowel}$ [kN]						
Steel	Concrete	Joint opening (mm)				
		5	10	15	20	30
S275	C20/25	86.43	82.70	79.14	75.75	69.48
	C25/30	96.13	91.50	87.12	82.97	75.37
	C30/37	104.81	99.30	94.10	89.22	80.36
	C32/40	108.06	102.19	96.68	91.51	82.16
	C35/40	112.72	106.33	100.35	94.75	84.68
	C40/50	120.02	112.77	106.00	99.71	88.49
S355	C20/25	98.73	94.96	91.35	87.89	81.42
	C25/30	109.87	105.20	100.74	96.49	88.62
	C30/37	119.86	114.29	109.00	103.99	94.77
	C32/40	123.60	117.67	112.05	106.74	97.00
	C35/40	128.97	122.51	116.41	110.65	100.14
	C40/50	137.39	130.05	123.14	116.65	104.90
S460	C20/25	112.92	109.12	105.46	101.94	95.29
	C25/30	125.74	121.02	116.50	112.16	104.04
	C30/37	137.23	131.61	126.24	121.11	111.57
	C32/40	141.54	135.55	129.84	124.40	114.31
	C35/40	147.73	141.21	134.99	129.09	118.18
	C40/50	157.44	150.02	142.98	136.32	124.08

B.2 Plate dowels

Discrete plate dowels are commonly used as alternatives to traditional bar dowels. These are not to be confused with continuous plate dowels which have been found to perform poorly in service and are not recommended.

The shear capacity is given by:

$$P_{sh\ plate} = A \times 0.9 \times 0.6 p_y \quad \text{Equation 3}$$

Where: A = cross-sectional area plate

p_y = plate steel design yield strength

The calculated values for $P_{sh\ plate}$ using Equation 3 are presented in Table B2.1.

Table B2.1: calculated values for $P_{sh\ dowel}$

Plate dimensions (mm)	A (mm ²)	f_{yk} (MPa) or p_y	$P_{sh\ plate}$ (kN)
150x6x120	900.0	275	133.65
		355	172.53
		460	223.56
150x8x120	1200.0	275	178.20
		355	230.04
		460	298.08
150x10x120	1500.0	275	222.75
		355	287.55
		460	372.60
150x12x120	1800.0	275	267.30
		355	345.06
		460	447.12

The bearing/bending capacity per plate dowel is given by:

$$P_{max\ dowel} = 0.5 [(b_1^2 + c_1)^{0.5} - b_1] \quad \text{Equation 4}$$

Where: $b_1 = 2ek_3f_{cd}P_b$

$$c_1 = 2k_3f_{cd}P_b^2 t_p^2 f_{yd}$$

e = half of joint opening width

$k_3 = 3$, a constant determined empirically

$f_{cd} = f_{ck}/\gamma_c$ = concrete design compressive cylinder strength

P_b = Plate width

t_p = Plate thickness

$f_{yd} = f_{yk}/\gamma_s$ = characteristic strength of steel plate

The calculated values for $P_{max, dowel}$ using Equation 4 are presented in Tables B2.2 to B2.6.

Table B2.2: Calculated values for Plate CH150x6 – $P_{max, dowel}$

		$P_{max, dowel}$ [kN]				
Steel	Concrete	Joint opening (mm)				
		5	10	15	20	30
S275	C20/25	53.41	43.18	35.50	29.75	22.05
	C25/30	58.19	46.02	37.20	30.80	22.50
	C30/37	62.29	48.31	38.51	31.58	22.82
	C32/40	63.77	49.12	38.96	31.84	22.93
	C35/40	65.87	50.23	39.56	32.19	23.06
	C40/50	69.05	51.85	40.42	32.68	23.25
S355	C20/25	62.30	51.55	43.18	36.70	27.69
	C25/30	68.08	55.21	45.50	38.20	28.37
	C30/37	73.07	58.21	47.32	39.33	28.86
	C32/40	74.88	59.26	47.94	39.71	29.02
	C35/40	77.45	60.73	48.79	40.22	29.24
	C40/50	81.36	62.89	50.01	40.94	29.53
S460	C20/25	72.62	61.39	52.35	45.13	34.71
	C25/30	79.57	66.04	55.46	47.23	35.73
	C30/37	85.59	69.90	57.94	48.85	36.47
	C32/40	87.80	71.28	58.79	49.39	36.72
	C35/40	90.93	73.19	59.97	50.13	37.04
	C40/50	95.71	76.03	61.67	51.18	37.49

Table B2.4: Calculated values for Plate CH150x8 – $P_{max,dowel}$

$P_{max,dowel}$ [kN]						
Steel	Concrete	Joint opening (mm)				
		5	10	15	20	30
S275	C20/25	75.25	63.91	54.72	47.33	36.57
	C25/30	82.50	68.83	58.05	49.60	37.69
	C30/37	88.79	72.92	60.70	51.35	38.51
	C32/40	91.10	74.38	61.63	51.95	38.78
	C35/40	94.37	76.40	62.89	52.75	39.14
	C40/50	99.38	79.43	64.73	53.90	39.64
S355	C20/25	87.22	75.47	65.68	57.58	45.37
	C25/30	95.84	81.61	70.02	60.67	46.99
	C30/37	103.37	86.76	73.54	63.09	48.20
	C32/40	106.13	88.61	74.77	63.92	48.60
	C35/40	110.06	91.19	76.47	65.05	49.14
	C40/50	116.11	95.07	78.96	66.68	49.89
S460	C20/25	101.07	88.95	78.58	69.80	56.11
	C25/30	111.29	96.54	84.19	73.95	58.43
	C30/37	120.25	102.98	88.80	77.25	60.18
	C32/40	123.56	105.30	90.42	78.39	60.77
	C35/40	128.26	108.56	92.67	79.96	61.57
	C40/50	135.52	113.48	96.00	82.23	62.68

Table B2.5: Calculated values for Plate CH150x10 – $P_{max\ dowel}$

$P_{max,dowel}$ [kN]						
Steel	Concrete	Joint opening (mm)				
		5	10	15	20	30
S275	C20/25	97.25	85.22	75.00	66.39	53.09
	C25/30	107.03	92.40	80.25	70.24	55.21
	C30/37	115.59	98.48	84.55	73.29	56.80
	C32/40	118.74	100.67	86.06	74.34	57.34
	C35/40	123.23	103.74	88.16	75.78	58.05
	C40/50	130.16	108.37	91.25	77.86	59.06
S355	C20/25	112.28	99.90	89.16	79.91	65.16
	C25/30	123.80	108.70	95.84	84.98	68.12
	C30/37	133.92	116.21	101.37	89.06	70.40
	C32/40	137.67	118.93	103.34	90.48	71.17
	C35/40	143.00	122.75	106.07	92.44	72.20
	C40/50	151.25	128.55	110.12	95.29	73.67
S460	C20/25	129.65	116.97	105.75	95.88	79.71
	C25/30	143.20	127.67	114.16	102.48	83.79
	C30/37	155.14	136.87	121.20	107.86	86.98
	C32/40	159.56	140.21	123.71	109.76	88.07
	C35/40	165.88	144.94	127.23	112.37	89.55
	C40/50	175.67	152.13	132.49	116.22	91.66

Table B2.6: Calculated values for Plate CH150x12 – $P_{max\ dowel}$

$P_{max,dowel}$ [kN]						
Steel	Concrete	Joint opening (mm)				
		5	10	15	20	30
S275	C20/25	119.33	106.82	95.87	86.36	71.00
	C25/30	131.67	116.39	103.25	92.03	74.40
	C30/37	142.53	124.57	109.38	96.63	77.03
	C32/40	146.55	127.54	111.56	98.24	77.92
	C35/40	152.28	131.73	114.61	100.45	79.12
	C40/50	161.15	138.09	119.14	103.70	80.84
S355	C20/25	137.41	124.61	113.21	103.11	86.36
	C25/30	151.86	136.17	122.41	110.42	91.00
	C30/37	164.62	146.13	130.14	116.41	94.63
	C32/40	169.35	149.76	132.92	118.53	95.88
	C35/40	176.10	154.90	136.79	121.46	97.57
	C40/50	186.58	162.73	142.61	125.78	100.01
S460	C20/25	158.30	145.24	133.42	122.78	104.70
	C25/30	175.19	159.14	144.81	132.09	110.92
	C30/37	190.15	171.19	154.46	139.81	115.87
	C32/40	195.70	175.60	157.95	142.56	117.59
	C35/40	203.65	181.85	162.84	146.37	119.94
	C40/50	216.00	191.43	170.22	152.06	123.34