

# European Technical Assessment

## ETA 20/0062 of 01/07/2021



English version prepared by Itecons

### General Part

**Technical Assessment Body issuing the European Technical Assessment:** Itecons - Instituto de Investigação e Desenvolvimento Tecnológico para a Construção, Energia, Ambiente e Sustentabilidade

<b>Trade name of the construction product</b>	FIXIN
<b>Product family to which the construction product belongs</b>	Kits for External Wall Claddings Mechanically Fixed  Product area code:09
<b>Manufacturer</b>	Mercantlis – Construções, Lda. Estrada Nacional 109, nº 1295, Doroana 2415-199 Regueira de Pontes Portugal
<b>Manufacturing plant</b>	Mercantlis – Construções, Lda. Estrada Nacional 109, nº 1295, Doroana 2415-199 Regueira de Pontes Portugal
<b>This European Technical Assessment contains</b>	19 pages including 3 Annexes which form an integral part of the assessment
<b>This European Technical Assessment is issued in accordance with regulation (EU) No 305/2011, on the basis of</b>	EAD 090062-00-0404 - <i>kits for External Wall Claddings Mechanically Fixed</i>
<b>This version replaces</b>	ETA 20/0062 issued on 29/03/2021

**Translations of this European Technical Assessment in other languages shall fully correspond to the original issued document and should be identified as such.**

**Communication of this European Technical Assessment, including transmission by electronic means, shall be in full (excepted the confidential Annex(es) referred to above). However, partial reproduction may be made, with the written consent of the issuing Technical Assessment Body. Any partial reproduction has to be identified as such.**

## Specific parts

### 1. Technical description of the product

The assessed kit for ventilated external wall claddings FIXIN consists of an external cladding suspended on the subframe which is fixed to the external wall of new or existing buildings (retrofit). This kit complies with the family G of EAD 090062-00-0404 – “Kits for External Wall Claddings Mechanically Fixed”. The cladding elements are suspended on the subframe by means of a hook-on arrangement with slotted fixings. An insulation layer can be fixed on the external wall, between the cladding elements and the thermal insulation layer of the external wall respectively, there is an air space which shall always be drained and may be ventilated.

The FIXIN kit consists of the following components, as detailed in Table 1: cladding elements, subframe elements, fixing elements and subframe fixing devices (brackets and fixings between subframe elements).

**Table 1:** Definition of the kit components

Component	Description	Material	Size
Cladding	Cassettes with top horizontal double folded flange, bottom horizontal simple/double folded flange, lateral simple folded flanges 40 mm depth or 44,5 mm depth (not reinforced slots width 15 mm), made from Thin Metallic Composite Panels (TMCP)	FIXbond FR: Composed by two alloyed aluminum sheets EN AW 3005 H42/H44 or 3105 H42/H44/H46 or 5005 H42/H44 (painted) and an internal core made of low density polyethylene (LPDE) plus mineral compounds	Standard width (mm): 1250 – 1500 Standard length (mm): 4000 – 5000 Tolerances (mm): Width = $\pm 2$ Length = +15 Diagonal = $\pm 3$
Subframe elements	Vertical profiles used to fix the cladding elements	Ref. PFL.FX.30-03: FIXIN CK.30-03 vertical profile made of raw finished extruded alloyed aluminium EN AW 6060 (AlMgSi) T6, with CE Marking	Thickness: 2 mm
	Elements used to fix cladding and/or subframe elements	Ref. CAR.FIXIN.01: FIXIN CB.01 hanging piece made of Alloyed aluminium EN AW 6060 (AlMgSi) T6 extruded, with CE marking, fixed to vertical profiles by screws ref. PERN.M5X8	Overall dimensions: 44 mm x 40 mm
		Ref. PERN.M5X8: Threaded shaft type DIN 916 14.9 M5X8 made of high resistance steel to fix the hanging piece to the vertical profiles	Length: min= 4.76 mm; max = 5.24 mm Outer diameter: max=4.976 mm min=4.82 mm
		Ref. REB.ALU.4.8x16: Aluminium blind rivet with carbon steel mandrel, dome head (DIN 7337), to close the edges of the cassettes	4.8 mm x 16 mm
	Ref. PF.7504O4.2x16A2: Self-drilling screws with countersunk head, type O (DIN 7504 A2 0 4.2x16), to fix the cassettes to the vertical profile	4.2 mm x 16 mm	

Component	Description	Material	Size
Subframe fixing devices	Brackets: elements used as load transmission between the subframe and the substrate wall	Ref. ESQ.FX.1.85: Fixin 1.85 U – shape profiles made of alloyed aluminum EN AW 6060 (AlMgSi) T6, with CE marking	Overall dimensions: 85 mm x 75 mm Thickness: 3 mm
	Fixings between subframe elements	Ref. PF.7504K.4.8x16.A2: Self-drilling screws hexagon flange head, type K (DIN 7504 A2 K 4.8X16) to fix the vertical profiles to the brackets	4.8 mm x 16 mm

## 2. Specification of the intended use(s) in accordance with the applicable European Assessment Document (hereinafter EAD)

### 2.1. Intended use

The cladding kit FIXIN is intended to be used in external wall claddings in ventilated façades (rainscreens). The kit can be fixed to external vertical walls made of masonry (bricks, concrete blocks and hollow blocks) or concrete (cast on site or as prefabricated panels) or timber or metal frame in new or existing buildings (retrofit).

The kit is non load-bearing element. It does not contribute to the stability of the wall on which it is installed. The cladding kit will normally contribute to the durability of the building by providing enhanced protection from the effect of weathering.

### 2.2. Relevant general conditions for the use of the kit

The provisions made in this European Technical Assessment are based on an assumed working life of 25 years as minimum according to the EAD, provided that the conditions lay down for the installation, packaging, transport and storage as well as appropriate use, maintenance and repair are met. The indications given on the working life cannot be interpreted as a guarantee given by the producer, but are to be regarded only as a mean for choosing the right product in relation to the expected economically reasonable working life of the works.

### 2.3. Design of the kit

The design of the external wall cladding system for façades using FIXIN kit should take into account:

- The substrate materials to define the suitable anchorages, assuming that the substrate meets the necessary airtightness and mechanical strength requirements, as well as a relevant watertightness and water vapour permeability;
- The mechanical characteristic values of the kit components, in order to resist all the actions (generally: dead loads or wind loads) applying on the specific work (National legislation and safety factor must be used);
- The possible movements of the substrate and the dilatations of the kit components;
- The construction of façade specific parts: corners, windows, base, top, etc.;
- If the entire building must comply with the specific building regulations, particularly concerning fire and wind-load resistances of the Member State where the work is to be built. The characteristic of the walls shall be verified prior to use of FIXIN kit, especially regarding conditions for reaction to fire classification and for mechanical fixings of the kit.

## **2.4. Installation of the kit in works**

Installation should be carried out according to the ETA holder's specifications and using the specific components of the kits, manufactured by the ETA holder or by suppliers recognized by the ETA holder. Installation should be carried out by appropriately qualified staff and under the supervision of the technical responsible of the site.

## **2.5. Use, maintenance and repair of the works**

Maintenance of the assembled system or components of the kit includes inspections on site, taking into account the following aspects:

- Regarding the cladding elements: Appearance of any damage such as cracking, delamination or detachment due to permanent and irreversible deformation;
- Regarding metallic components: Presence of corrosion or water accumulation.

Necessary repairs should be done rapidly, using the same kit components and following the repair instructions given by ETA holder.

## **3. Performance of the product and references to the methods used for its assessment**

The assessment of FIXIN kit according to the Basic Works Requirements (BWR) was carried out in compliance with EAD 090062-00-0404. The characteristics of the components shall correspond to the respective values laid down in the technical documentation of this ETA, checked by Itecons.

### **3.1. Safety in case of fire (BWR 2)**

#### **3.1.1. Reaction to fire**

According to EAD 090062-00-0404, the reaction to fire of the kit is assessed by considering the reaction to fire of the components of the kit (cladding element, cladding fixings, subframe components, thermal insulation products, etc), being the whole kit classified based on the worst class of any component<sup>1</sup>.

According to Decision 96/603/EC the metallic components of the subframe (subframe elements and subframe fixing devices) are classified A1 without the need for testing.

The reaction to fire class of the cladding element, FIXbond FR, assessed according to EN 13501-1, is B-s1,d0.

In conclusion, according to EAD 090062-00-0404, the reaction to fire of the FIXIN kit, as described in Table 1, is B-s1,d0.

#### **3.1.2. Façade fire performance**

No performance determined.

#### **3.1.3. Propensity to undergo continuous smouldering**

No performance determined.

---

<sup>1</sup> A European reference fire scenario has not been laid down for facades. In some Member States, the classification of the cladding kits according to standard EN 13501-1 might not be sufficient for the use in facades. As additional assessment of the kits according to the national provision (e.g. on the basis of a large scale test) might be necessary to comply with Member State Regulations, until the existing European classification system has been completed.

## 3.2. Hygiene, health and environment (BWR 3)

### 3.2.1. Watertightness of joints (protection against driving rain)

Joints between the cladding elements in the external wall claddings for ventilated façades are open, therefore FIXIN kit is not watertight.

### 3.2.2. Water absorption

Not relevant for ventilated façades.

### 3.2.3. Water vapour permeability

Not relevant for ventilated façades.

### 3.2.4. Drainability

On the basis of the construction details (see Annex 2), the available technical knowledge and experience and the installation criteria, it is considered that the water which penetrates into the air space or the condensation water can be drained out from the cladding without accumulation, moisture damage or leakage into the substrate.

### 3.2.5. Content, emission and/or release of dangerous substances

No performance determined.

## 3.3. Safety in use (BWR 4)

### 3.3.1. Wind load resistance

The wind load suction and pressure resistance of assembled cladding kit was tested according to the method indicated in section 2.2.9 of the EAD 090062-00-0404. The results for the tested specimen (see Annex 3) are presented in Table 2 and Table 3.

**Table 2:** Summary of wind suction resistance results

Test specimen	Maximum wind load resistance Q (Pa)
FIXbond FR LxH = 1400x650 mm revited on corners – Perimeter rivets vertical distance: 560 mm – Perimeter rivets horizontal distance: 1400 mm – Distance between hanging pieces: 400 mm – Distance between vertical profiles: 1406 mm – Distance between brackets: 878 mm	1800

**Table 3:** Summary of wind pressure resistance results

Test specimen	Maximum wind load resistance Q (Pa)
FIXbond FR LxH = 1400x650 mm revited on corners – Perimeter rivets vertical distance: 560 mm – Perimeter rivets horizontal distance: 1400 mm – Distance between hanging pieces: 400 mm – Distance between vertical profiles: 1406 mm – Distance between brackets: 878 mm	1800

### 3.3.2. Resistance to horizontal point loads

The resistance to horizontal point loads was assessed according to the method indicated in section 2.2.10 of the EAD 090062-00-0404. The results for the tested specimen (see Annex 3) are presented in Table 4.

**Table 4:** Resistance of horizontal point loads

Panel type	Deformation (mm)
FIXbond FR = 1400x650 mm revited on corners <ul style="list-style-type: none"> <li>– Perimeter rivets vertical distance: 560 mm</li> <li>– Perimeter rivets horizontal distance: 1400 mm</li> <li>– Distance between hanging pieces: 400 mm</li> <li>– Distance between vertical profiles: 1406 mm</li> <li>– Distance between brackets: 878 mm</li> </ul>	No permanent deformation (no visible deformation) on any component

### 3.3.3. Impact resistance

The impact resistance was assessed according to the method indicated in section 2.2.11 of the EAD 090062-00-0404. The results for the tested specimen (see Annex 3) and use categories obtained are presented in Table 5.

**Table 5:** Impact test results

Test specimen	Impact	Energy	Ball	Degree of exposure in use
FIXbond FR LxH = 1400x650 mm revited on corners <ul style="list-style-type: none"> <li>– Perimeter rivets vertical distance: 560 mm</li> <li>– Perimeter rivets horizontal distance: 1400 mm</li> <li>– Distance between hanging pieces: 400 mm</li> <li>– Distance between vertical profiles: 1406 mm</li> <li>– Distance between brackets: 878 mm</li> </ul>	Hard body	1 J	0.5 kg	No deterioration (superficial damage without cracking)
		3 J	0.5 kg	No deterioration (superficial damage without cracking)
		10 J	1.0 kg	No deterioration (superficial damage without cracking)
	Soft body	10 J	3.0 kg	No deterioration (superficial damage without cracking)
		60 J	3.0 kg	No deterioration (superficial damage without cracking)
		300 J	50.0 kg	No deterioration (significant permanent deflection without cracking)
		400 J	50.0 kg	No deterioration (significant permanent deflection without cracking)
	Use category			

### 3.3.4. Mechanical resistance

The assessment of the mechanical resistance of the FIXIN kit was carried out by means of the assessment of the mechanical resistance of the relevant kit components (cladding element, cladding fixings and subframe components) and connections between them, which are representative of this essential characteristic for cladding kits.

### 3.3.4.1. Mechanical resistance of the cladding element: Bending strength of cladding element (TMCP)

The bending strength of the cladding element (TMCP) FIXbond FR is assessed in section 3.6 of this ETA.

### 3.3.4.2. Mechanical resistance of the connection between the cladding element and the cladding fixing: Resistance of the slot

The resistance of the slot was assessed according to section 2.2.12.9 of the EAD 090062-00-0404. The results are shown in Table 6.

**Table 6:** Mechanical fixing resistance of the slot – horizontal resistance

Type of specimen	Failure load (N)			
	F <sub>m</sub>	S	k <sub>n</sub>	F <sub>u,5</sub>
FIXbond FR	1073	83	2.33	880

Key: F<sub>m</sub> – Mean value; S – Standard deviation; k<sub>n</sub> – the variable as a function of the number of test specimens for 5% with 75% confidence level when the population standard deviation is unknown; F<sub>u,5</sub> – Characteristic value (75% confidence that 95% of test results will be higher than this value).

### 3.3.4.3. Mechanical resistance of subframe components: Resistance of profiles

The resistance of aluminium profiles was assessed according section 2.2.12.13 of the EAD 090062-00-0404 on basis of the properties presented in Table 7.

**Table 7:** Resistance of aluminium profiles

Profile ref.	Type	Effective moment of Inertia (cm <sup>4</sup> )		E modulus (MPa) (EN 1999 1-1)	Alloy EN AW	Mechanical characteristics (minimum)				
		I <sub>x</sub>	I <sub>y</sub>			R <sub>m</sub> (N/mm <sup>2</sup> )	R <sub>p0,2</sub> (N/mm <sup>2</sup> )	A (%)	A <sub>50mm</sub> (%)	HBW
PFL.FX.30-03	Extruded alloyed aluminium EN AW 6060 (AlMgSi) T6 Thickness: 2.0 mm	3.88	25.08	70000	6060 (AlMgSi) T6	≥ 190	≥ 150	≥ 8	≥ 6	70

### 3.3.4.4. Mechanical resistance of subframe components: Tension/pull-out resistance of subframe fixings

The tension/pull-out resistance of subframe fixings – connection between hanging piece and vertical profile and connection between vertical profile and brackets – was assessed according section 2.2.12.14 of the EAD 090062-00-0404. The connection between hanging piece and vertical profile was assessed for tension (wind suction). The results are presented in Table 8.

**Table 8:** Tension resistance of the connection fixings from the vertical profiles – Connection between hanging piece and vertical profile

Type of fixing	Failure load (N)			
	F <sub>m</sub>	S	k <sub>n</sub>	F <sub>u,5</sub>
Connection between hanging piece and vertical profile Vertical profile: PFL.FX.30-03 Hanging piece: CAR.FIXIN.01 Threaded shaft: PERN.M5X8	2711	331	2.33	1940

Key: F<sub>m</sub> – Mean value; S – Standard deviation; k<sub>n</sub> – the variable as a function of the number of test specimens for 5% with 75% confidence level when the population standard deviation is unknown; F<sub>u,5</sub> – Characteristic value (75% confidence that 95% of test results will be higher than this value).

The connection between the vertical profile and brackets was assessed through the two limit sets, (the maximum and minimum spacing), although the kit allows the application in intermediate. Figure 1 shows the two extreme situations.



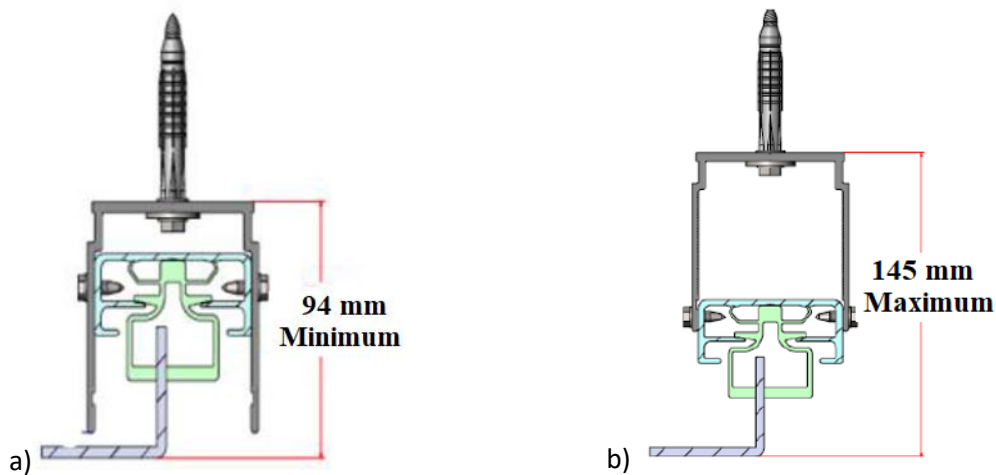

**Figure 1:** Tested configurations for the assessment of the connection between vertical profile and brackets: a) minimum spacing; b) maximum spacing.

The tension/pull-out resistance of the fixings between profiles and brackets was assessed for the two limit configurations presented in Figure 1, according section 2.2.12.14 of the EAD 090062-00-0404. The results are presented in Table 9.

**Table 9:** Tension / pull out of the connection between vertical profile and brackets

Configuration	Load direction	Failure load (N)			
		F <sub>m</sub>	S	k <sub>n</sub>	F <sub>u,5</sub>
Minimum spacing Vertical profile: PFL.FX.30-03 Bracket: ESQ.FX.1.85 4 Self-drilling screws: PF.7504K.4.8x16.A2	Tension (Wind suction)	15947	1538	2.33	12364
Maximum spacing Vertical profile: PFL.FX.30-03 Bracket: ESQ.FX.1.85 4 Self-drilling screws: PF.7504K.4.8x16.A2	Tension (Wind suction)	16636	1276	2.33	13663
Minimum spacing Vertical profile: PFL.FX.30-03 Bracket: ESQ.FX.1.85 4 Self-drilling screws: PF.7504K.4.8x16.A2	Pull-out (Wind pressure)	8466	1733	2.63	3909
Maximum spacing Vertical profile: PFL.FX.30-03 Bracket: ESQ.FX.1.85 4 Self-drilling screws: PF.7504K.4.8x16.A2	Pull-out (Wind pressure)	6926	403	2.33	5986

Key: F<sub>m</sub> – Mean value; S – Standard deviation; k<sub>n</sub> – the variable as a function of the number of test specimens for 5% with 75% confidence level when the population standard deviation is unknown; F<sub>u,5</sub> – Characteristic value (75% confidence that 95% of test results will be higher than this value).

### 3.3.4.5. Mechanical resistance of subframe components: Shear load resistance of subframe fixings

The shear resistance of subframe fixings – connection between hanging piece and vertical profile and connection between vertical profile and brackets – was assessed according to section 2.2.12.15 of EAD 090062-00-0404.

The connection between hanging piece and vertical profile was performed considering that the load during test was applied with a nominal eccentricity of 42 mm, corresponding to the distance between the edge of the hanging piece to the threaded shaft, see Figure 2. The results are presented in Table 10.

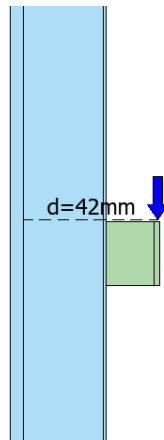

**Figure 2:** Load application point during shear test.

**Table 10:** Shear resistance of the connection between hanging piece and vertical profile

Type of fixing	Failure load (N)			
	$F_m$	S	$k_n$	$F_{u,5}$
Connection between hanging piece and vertical profile Vertical profile: PFL.FX.30-03 Hanging piece: CAR.FIXIN.01 Threaded shaft: PERN.M5X8	1077	76	2.33	900

Key:  $F_m$  – Mean value; S – Standard deviation;  $k_n$  – the variable as a function of the number of test specimens for 5% with 75% confidence level when the population standard deviation is unknown;  $F_{u,5}$  – Characteristic value (75% confidence that 95% of test results will be higher than this value).

The shear resistance of the fixings between profiles and brackets was assessed for the two limit configurations presented in Figure 3. This test was performed considering that the load during the test was applied with a nominal eccentricity of 75 mm and 25 mm, in case of maximum and minimum spacing configuration, respectively, see Figure 3. The results are presented in Table 11.

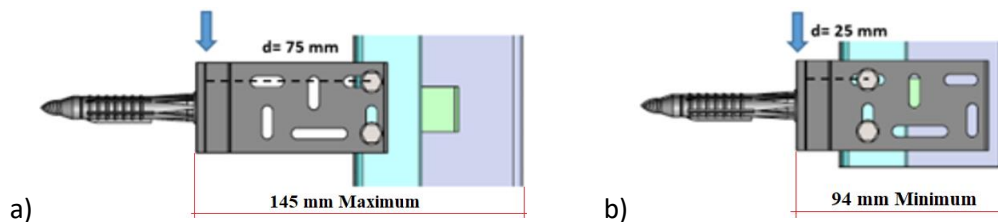

**Figure 3:** Tested configurations for the assessment of the connection between vertical profile and brackets with the indication of shear load eccentricity: a) maximum spacing; b) minimum spacing.

**Table 11:** Shear resistance of the connection between vertical profile and brackets

Type of fixing	Failure load (N)			
	$F_m$	S	$k_n$	$F_{u,5}$
Minimum spacing Vertical profile: PFL.FX.30-03 Bracket: ESQ.FX.1.85 4 Self-drilling screws: PF.7504K.4.8x16.A2	12091	852	2.33	10107
Maximum spacing Vertical profile: PFL.FX.30-03 Bracket: ESQ.FX.1.85 4 Self-drilling screws: PF.7504K.4.8x16.A2	2560	147	2.33	2218

Key:  $F_m$  – Mean value; S – Standard deviation;  $k_n$  – the variable as a function of the number of test specimens for 5% with 75% confidence level when the population standard deviation is unknown;  $F_{u,5}$  – Characteristic value (75% confidence that 95% of test results will be higher than this value).

### 3.3.4.6. Mechanical resistance of subframe components: Bracket resistance (vertical and horizontal loads)

The configuration considered for the bracket resistance assessment corresponds to the coupling of two brackets, as shown in Figure 4. During test was considered that the connection to substrate was rigid. The results are according to the criteria presented in annex L of the EAD 090062-00-0404 and are presented in Table 12 and Table 13.

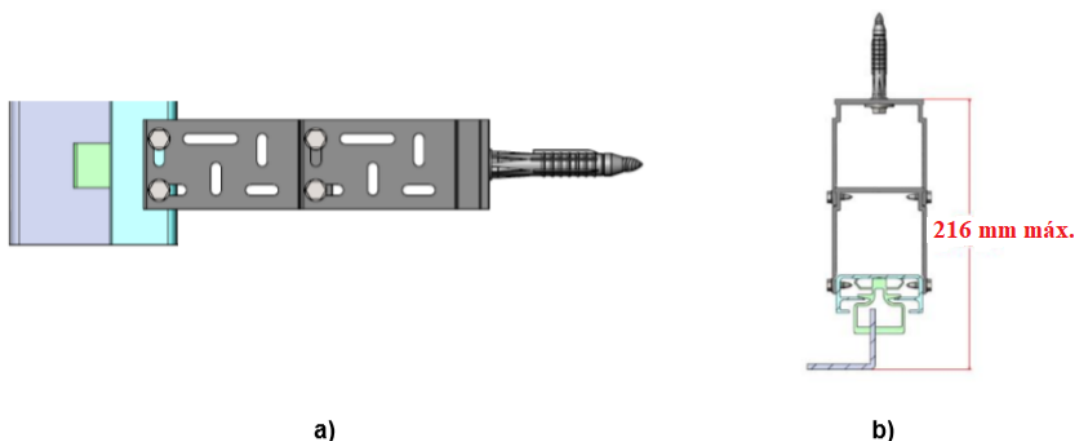

**Figure 4:** Figure 4: Tested configuration for the assessment of the bracket resistance: a) side view; b) top-view

**Table 12: Resistance to horizontal load (tension) of brackets**

Criterion	Failure load (N)			
	$F_{sm}$	S	$k_n$	$F_{u,5}$
1º ( $F_m$ )*	-	-	-	-
2º ( $F_t$ ) Vertical profile: PFL.FX.30-03 2 brackets: ESQ.FX 1.85 8 Self-drilling screws: PF.7504K.4.8X16.A2	14303	402	2.33	13366

Key:  $F_{sm}$  – Mean value; S – Standard deviation;  $k_n$  – the variable as a function of the number of test specimens for 5% with 75% confidence level when the population standard deviation is unknown;  $F_{u,5}$  – Characteristic value (75% confidence that 95% of test results will be higher than this value).

\*Not accomplished.

**Table 13:** Resistance to vertical load (shear) of brackets

Criterion	Failure load (N)			
	F <sub>sm</sub>	S	k <sub>n</sub>	F <sub>u,5</sub>
<b>1° (F<sub>r</sub>)</b> Vertical profile: PFL.FX.30-03 2 brackets: ESQ.FX 1.85 8 Self-drilling screws: PF.7504K.4.8X16.A2	1380	415	2.33	414
<b>2° (F<sub>1d</sub>)</b> Vertical profile: PFL.FX.30-03 2 brackets: ESQ.FX 1.85 8 Self-drilling screws: PF.7504K.4.8X16.A2	562	83	2.33	368
<b>2° (F<sub>3d</sub>)</b> Vertical profile: PFL.FX.30-03 2 brackets: ESQ.FX 1.85 8 Self-drilling screws: PF.7504K.4.8X16.A2	1697	196	2.33	1240
<b>3° (F<sub>s</sub>)</b> Vertical profile: PFL.FX.30-03 2 brackets: ESQ.FX 1.85 8 Self-drilling screws: PF.7504K.4.8X16.A2	2946	84	2.33	2750

Key: F<sub>sm</sub> – Mean value; S – Standard deviation; k<sub>n</sub> – the variable as a function of the number of test specimens for 5% with 75% confidence level when the population standard deviation is unknown; F<sub>u,5</sub> – Characteristic value (75% confidence that 95% of test results will be higher than this value).

### 3.4. Protection against noise (BWR 5)

#### 3.4.1. Airborne sound insulation

No performance determined.

### 3.5. Energy economy and heat retention (BWR 6)

#### 3.5.1. Thermal resistance

Not relevant as the cladding kit does not include the thermal insulation according to section 2.2.14 of the EAD 090062-00-0404.

### 3.6. Aspect of durability and serviceability

The assessment of the durability of the kit is carried out by means of the assessment of the following characteristics which are representative of this essential characteristic for claddings kits:

- Hygothermal behaviour of the kit;
- Behaviour of the kit after pulsating loads;
- Durability of the kits components.

The cladding element of the FIXIN kit is made of TMCP. The accelerated ageing behaviour of the cladding element FIXbond FR is listed in the following Tables<sup>2</sup>.

#### 3.6.1. Corrosion

**Table 14:** Corrosion resistance of subframe components made of aluminium

Element	Alloy EN AW	Corrosion resistance
Aluminium profiles and Brackets	6060 (AlMgSi) T6	Class B

<sup>2</sup> The results indicated in Table 15, Table 16, Table 17, Table 18, Table 19, Table 20, Table 21, Table 23, Table 24, and Table 25 were taken from ETA 15/0655 version 6 (cladding reference “FR”).

### 3.6.2. Decay of delamination resistance after hygrothermal cycles

**Table 15:** Decay of delamination resistance after hygrothermal cycles

Panel Type	Characteristic	Mean value after ageing		Remarks
FIXbond FR	Delamination resistance	Front sheet: > 75% initial value	Rear sheet: > 75% initial value	No cracks, or breakage

### 3.6.3. Decay of delamination resistance after immersion in boiling water 6h at 90°C

**Table 16:** Decay of delamination resistance after immersion in water 6 h at 90°C

Panel Type	Characteristic	Mean value after ageing		Remarks
FIXbond FR	Delamination resistance	Front sheet: > 75% initial value	Rear sheet: > 75% initial value	No cracks, or breakage

### 3.6.4. Decay of delamination after immersion in water 500 h at 20°C

**Table 17:** Decay of delamination resistance after immersion in water 500 h at 20°C

Panel Type	Characteristic	Mean value after ageing		Remarks
FIXbond FR	Delamination resistance	Front sheet: > 75% initial value	Rear sheet: > 75% initial value	No cracks, or breakage

### 3.6.5. Decay of delamination resistance after freeze-thaw cycles

**Table 18:** Decay of delamination resistance after freeze-thaw cycles

Panel Type	Characteristic	Mean value after ageing		Remarks
FIXbond FR	Delamination resistance	Front sheet: > 75% initial value	Rear sheet: > 75% initial value	No cracks, or breakage

### 3.6.6. Decay of delamination resistance after long term exposure to heat (2500 h at hot dry air 80°C)

**Table 19:** Decay of delamination resistance after long term exposure to heat (2500 h at hot dry air 80°C)

Panel Type	Characteristic	Mean value after ageing		Remarks
FIXbond FR	Delamination resistance	Front sheet: > 75% initial value	Rear sheet: > 75% initial value	No cracks, or breakage

### 3.6.7. Decay of flexural stiffness

**Table 20:** Decay of flexural stiffness

Panel Type	Characteristic	$d_{80\text{ ME}} (1\text{ h } 80^\circ\text{C})$		Remarks
FIXbond FR	Increase of deflection after 1 h 80°C	$\leq 1.25 d_{20\text{ ME}}$		No cracks, or breakage

### 3.6.8. Decay of resistance to routed and returned edge after TPB test, flexural pulsating loads

**Table 21:** Decay of resistance to routed and returned edge after TPB test, flexural pulsating loads

Characteristic	Panel Type	Characteristic	Remarks
		Aged characteristic force $F_{u,5}$	
TPB test Flexural pull out pulsating loads	FIXbond FR	> 75% Initial value	No cracks, breakage, or delamination

### 3.6.9. Decay of resistance to slot and its fixing devices after pulsating loads

**Table 22:** Decay of resistance to slot and its fixing devices after pulsating loads

Characteristic	Panel Type	Direction of the load	Load (N)
			Aged characteristic force $F_{u,5}$
Non reinforced slot	FIXbond FR	Horizontal (wind pressure/suction)	> 75% Initial value

### 3.6.10. Corrosion infiltration after exposure to spray salt

**Table 23:** Corrosion resistance of cladding element made of coil coated aluminium – corrosion infiltration

Panel Type	Material	Corrosion infiltration
FIXbond FR	PVDF	No defects after 500 and 1000 h*

\*Key: Index 3 according to EN 1396: Aluminium and aluminium alloys. Coil coated sheet and strip for general applications. Specifications

### 3.6.11. Degree of blistering after exposure to humidity

**Table 24:** Corrosion resistance of cladding element made of coil coated aluminium - blistering

Panel Type	Material	Blistering
FIXbond FR	PVDF	No defects after 500 and 1000 h*

\*Key: Index 3 according to EN 1396: Aluminium and aluminium alloys. Coil coated sheet and strip for general applications. Specifications

### 3.6.12. Retention of bright and colour

**Table 25:** Retention of bright and colour

Characteristic	Commercial ref.	Humidity	UVB & water 1500 h	Heat	Remarks
Retention of bright (gloss units)	Ultramarine Ral 9016 Silver metallic	GLOSS AGED ≥ 0.8 GLOSS INI	GLOSS AGED ≥ 0.8 GLOSS INI	GLOSS AGED ≥ 0.8 GLOSS INI	OK
Retention of colour $\Delta E$	Ultramarine Ral 9016 Silver metallic	OK --	OK --	OK --	OK Not required

#### 4. Assessment and verification of constancy of performance (hereinafter AVCP) system applied, with reference to its legal base

According to the Decision 2003/640/EC of European Commission the system of assessment and verification of constancy of performance (see Annex V to Regulation (EU) No 305/2011) given in the following Table applies:

**Table 26: AVCP Systems**

Product	Intended use	Levels(s) or class(es)	System
Kit for external wall cladding FIXIN	Any use not subject to fire regulations	----	2+

#### 5. Technical details necessary for the implementation of the AVCP system, as provided for in the applicable EAD

The ETA is issued on the basis of agreed data/information, deposited at Itecons, which identifies the product that has been assessed and judged. It is the manufacturer's responsibility to make sure that all those who use the kit are appropriately informed of specific conditions laid down in this ETA.

Changes to the kit for external wall claddings mechanically fixed or the components or their production process should be notified to the Itecons before the changes are introduced. Itecons will decide whether or not such changes affect the ETA and if so whether further assessment or alterations to the ETA shall be necessary.

Issued in Coimbra on 01.07.2021

By

Technical Assessment Unit of

Itecons – Instituto de Investigação e Desenvolvimento Tecnológico para a Construção, Energia, Ambiente e Sustentabilidade



Andreia Gil  
Senior Official

(Technical Assessment Unit Coordinator)



Validated document

(Administration)

## Annex 1: General schemes

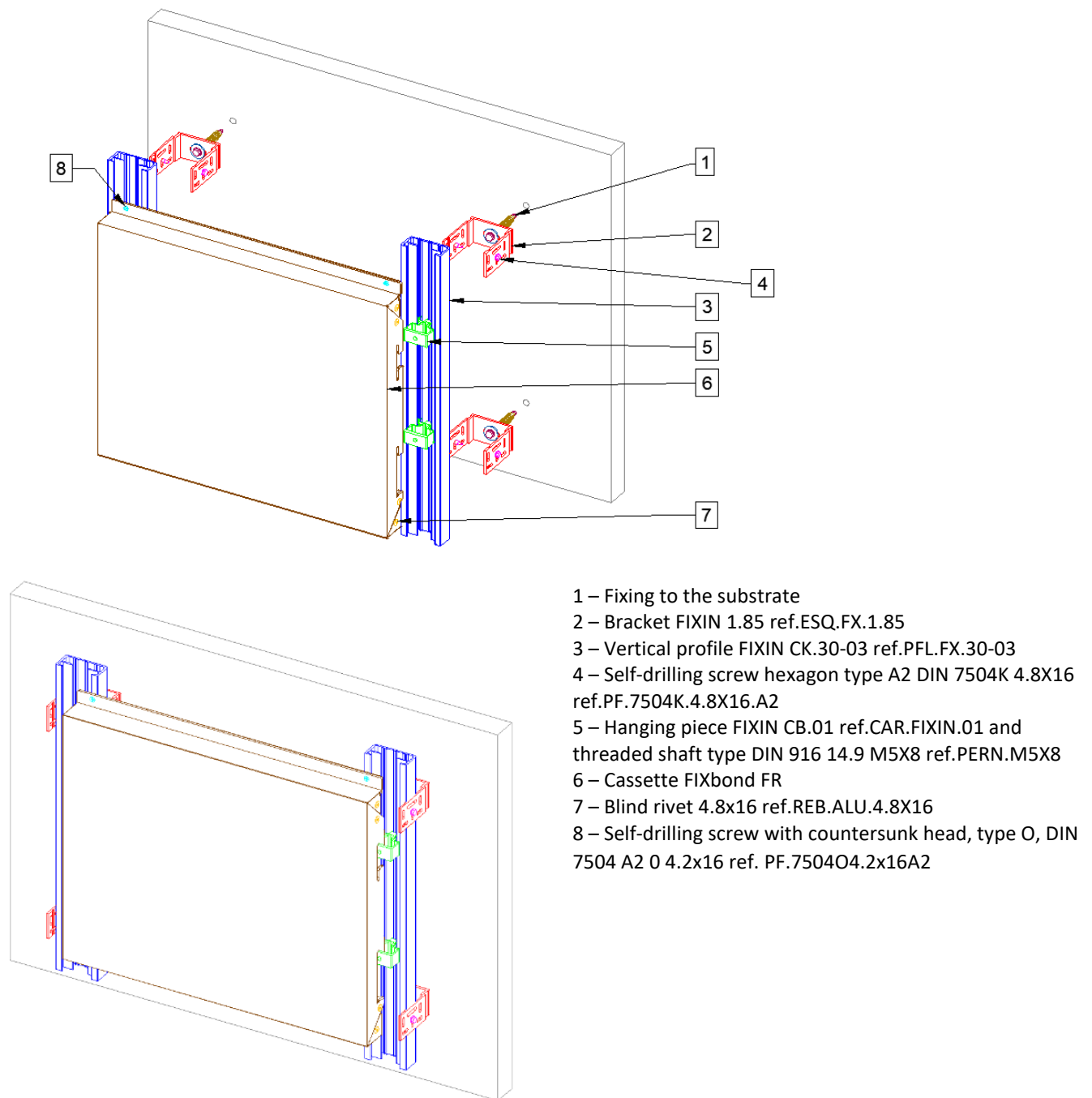

- 1 – Fixing to the substrate
- 2 – Bracket FIXIN 1.85 ref.ESQ.FX.1.85
- 3 – Vertical profile FIXIN CK.30-03 ref.PFL.FX.30-03
- 4 – Self-drilling screw hexagon type A2 DIN 7504K 4.8X16 ref.PF.7504K.4.8X16.A2
- 5 – Hanging piece FIXIN CB.01 ref.CAR.FIXIN.01 and threaded shaft type DIN 916 14.9 M5X8 ref.PERN.M5X8
- 6 – Cassette FIXbond FR
- 7 – Blind rivet 4.8x16 ref.REB.ALU.4.8X16
- 8 – Self-drilling screw with countersunk head, type O, DIN 7504 A2 0 4.2x16 ref. PF.7504O4.2x16A2

**Figure A1.1:** General scheme of FIXIN kit.



## Annex 2: Drainability of the FIXIN kit

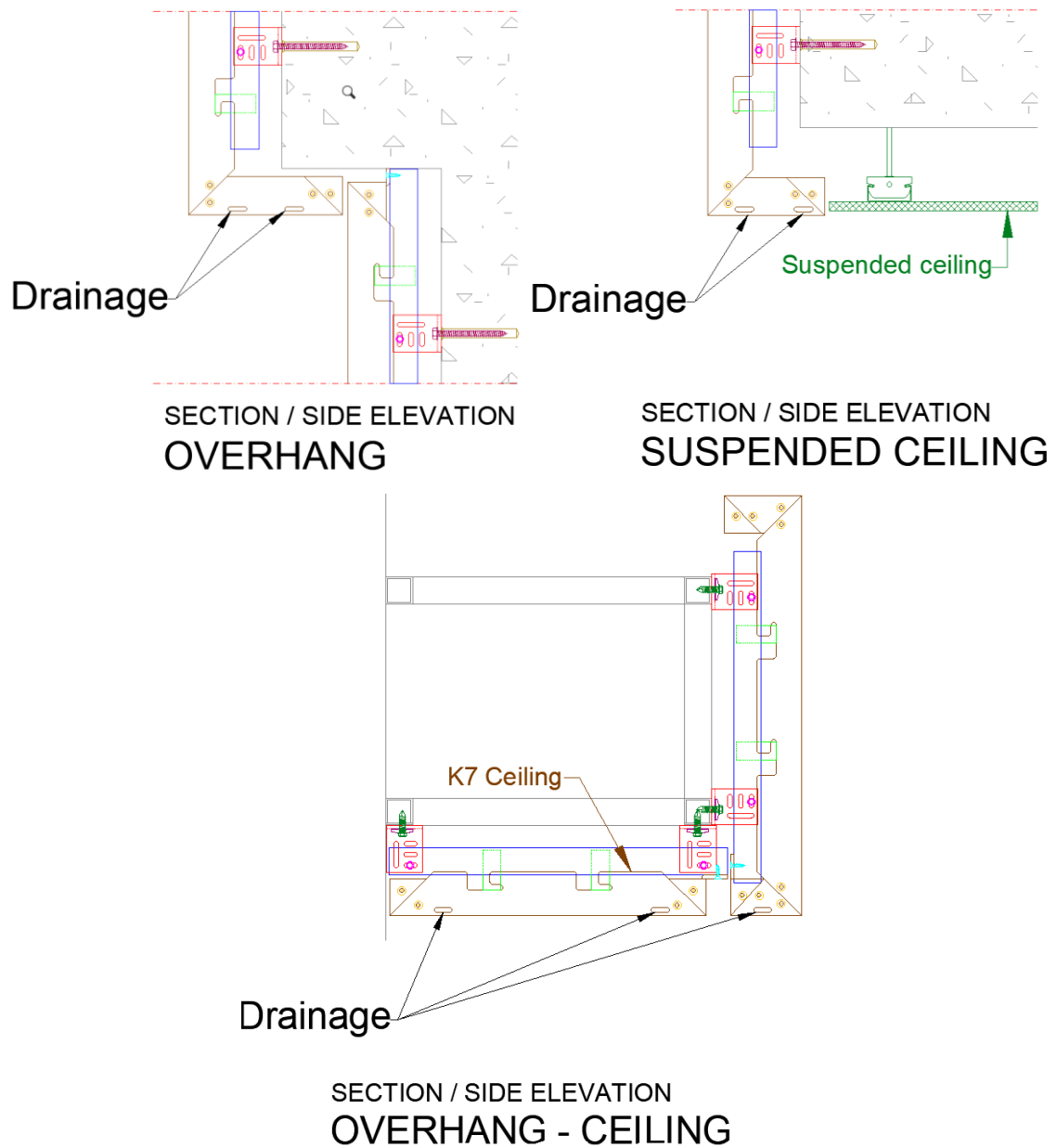
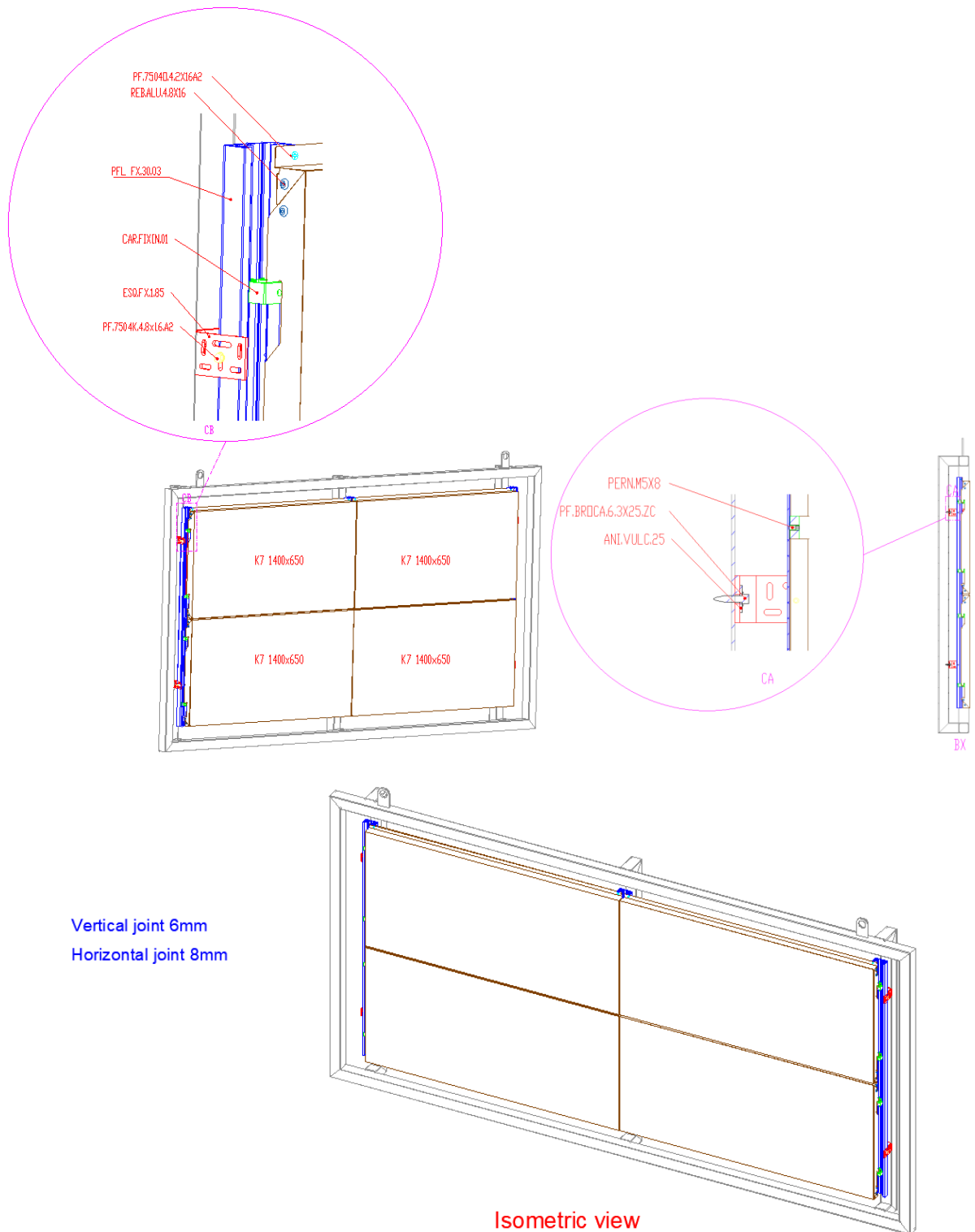
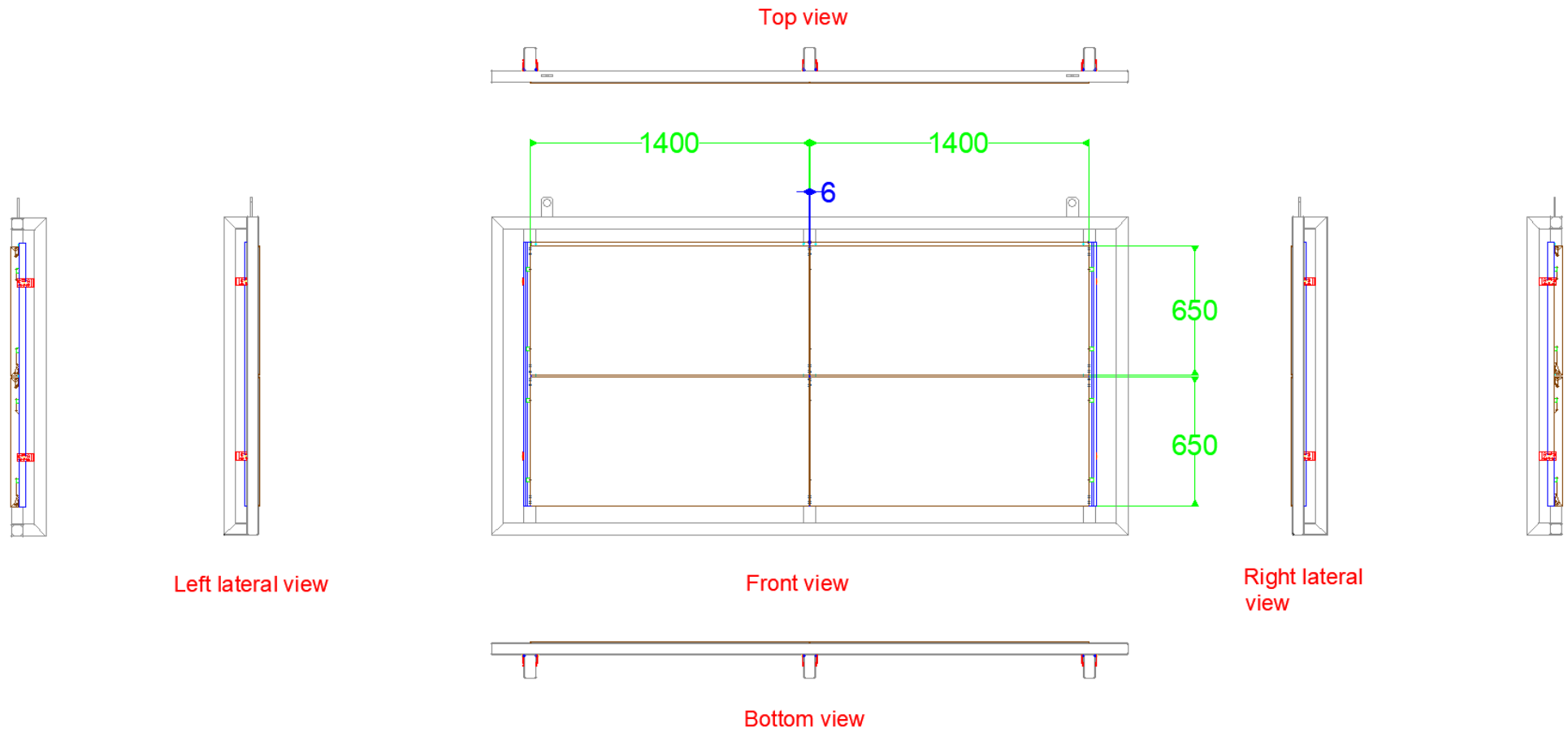

Figure A2.1: Drainage details.

**Annex 3: Scheme of the test specimen of the wind load resistance test, horizontal point loads test and impact resistance test**



**Figure A3.1:** Scheme of the test specimen of the wind load resistance test, horizontal point loads test and impact resistance test



**Figure A3.2:** Scheme of the test specimen of the wind load resistance test, horizontal point loads test and impact resistance test